

適用配件

修邊座適用

集塵管接頭
19559-1



直規
122965-7



修邊導具
122703-7



樣規導具
343577-5
10mm



雕刻座適用

集塵管接頭
194733-8



導規
195564-8



直規
122965-7



可微調直線導具
195136-9



導軌適配器
194579-2



導軌板
1.0m 199140-0
1.5m 199141-8
1.9m 194926-7
3.0m 194367-7

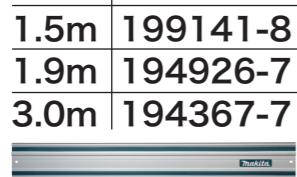

軌道板連結器
198884-9

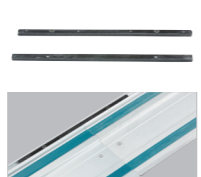

角度規
196664-7

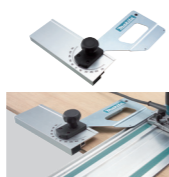

快速夾具
199826-6



標準夾具
194385-5



樣規導具 (雕刻座適用)

料號	尺寸(mm)
164775-6	11
164388-3	12
164776-4	12.7
165366-6	17
164393-0	20
165364-0	24
164470-8	27
163080-8	29
164471-6	30
165046-4	40
164472-4	40

底座保護板

底座保護板
(修邊座適用)
454842-8



底座保護板
(雕刻座適用)
450819-1



底座保護板
(角度座適用)
413150-6



底座保護板
(貼邊輔助座適用)
413148-3



夾子套管



尺寸	料號
8mm	763618-5
6mm	763636-3
1/4"	763637-1

其他

握把座
318685-1



握把
153489-2



充電式無刷木工修邊機

RT001GZ14

- 無段變速
- 緩啟動
- 定速
- 連結集塵
- 煞車
- 作業燈照明

夾頭直徑	6 mm / 8 mm
回轉速 (RPM)	10,000 - 31,000 rpm
尺寸(長 x 寬 x 高)	124-140 x 89 x 197-251 mm
重量	2.2 - 2.5 kg

標配：集塵管接頭(修邊座用)、直規、扳手13mm/22mm、樣規導具10mm(修邊座用)
夾子套管6mm/8mm

※ Z 為單機不附電池與充電器

Makita

充電式無刷木工修邊機
RT001G

XGT
40V 鋰電池

XGT
40V Li-ion
max

切割速度提升 35%



Makita

台灣牧田股份有限公司
www.makita.com.tw

f 牧田FB 台灣牧田 搜尋

2022-09-V1

1 充電使用時間(4.0Ah)
白柳安凹槽(Ø6x深6mm)
約 170m

AWS
無線連動技術

BL
MOTOR
無碳刷馬達

XPT
防塵防水滴



BL MOTOR
無碳刷馬達

開關操作

鎖定 / 解鎖按鈕
啟動 / 停止按鈕

5 段速度調節盤

高耐用鋁製外殼

軸鎖



雙 LED 工作燈



夾頭

6mm/8mm



緩啟動

可減輕啟動震動
流暢的啟動工具

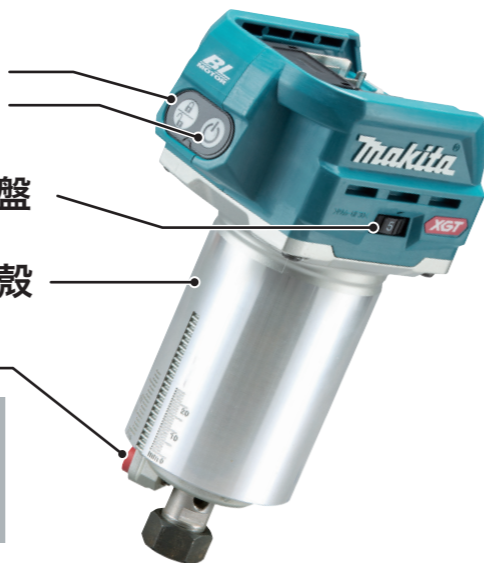

修邊座

圓形底座，切割順暢、快速且易於操作



防滑彈性握把提高了操作的舒適度

切割深度調整

底座鎖扣

鋁製底座，精巧且高耐用

用於保護底座的
可更換型塑料底板
有助於機器在工作表面平滑滑動

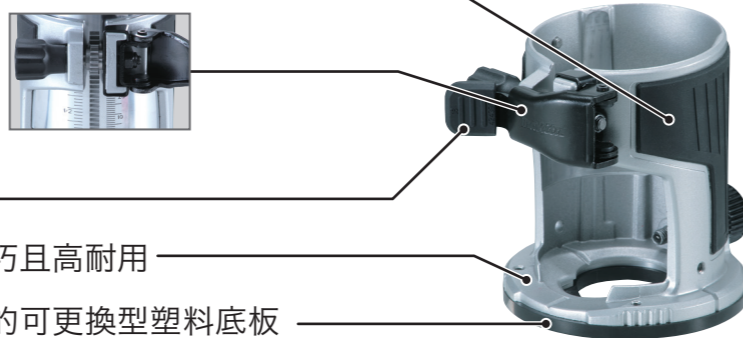

角度座

單手即可輕鬆抓握，傾斜角度 -30° 至 45°



防滑彈性握把提高了操作的舒適度

切割深度調整

底座鎖扣

鋁製底座，精巧且高耐用

用於保護底座的
可更換型塑料底板
有助於機器在工作表面平滑滑動

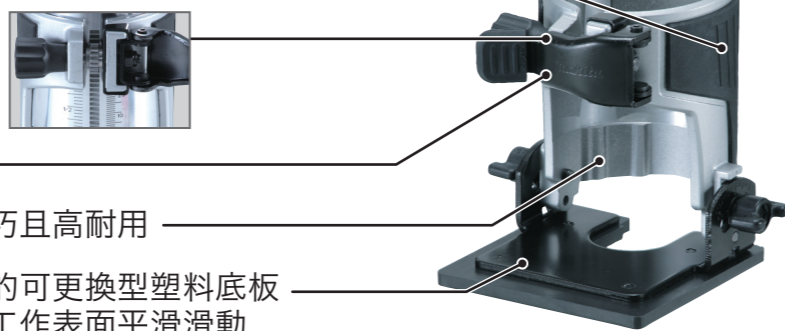

AWS 無線連動技術

通過藍牙連接到吸塵器
開關打開時吸塵器自動運行



開啟
機器



吸塵器
開始
運作

Bluetooth®

藍牙晶片 (選購)
199393-1



恆速控制

最大限度減少速度降低，使切割速度維持平穩

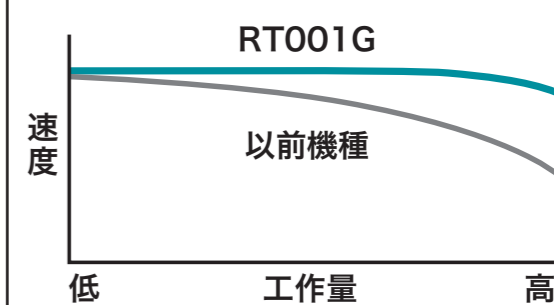

可選購不同基座增加功能



修邊座
196612-6
標配



雕刻座
195563-0
選購



角度座
198987-9
選購



貼邊輔助座
195562-2
選購



雕刻座

精密切割深度調整



好抓握的圓形手柄



可使用微調直線導具
(選購)

鎖桿
易於操作

橡膠握把

3 段切割深度調整

鋁製底座
精巧且高耐用

用於保護底座的
可更換型塑料底板
有助於機器在工作表
面平滑滑動

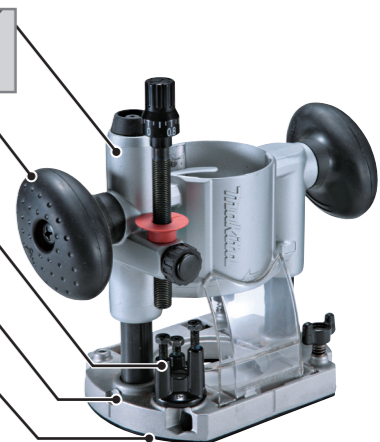
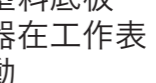
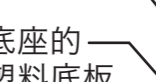
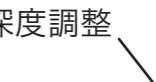

貼邊輔助座

可靠近牆壁或角落進行穩定切割



防滑彈性握把提高了操作的舒適度

底座鎖扣

鋁製底座，精巧且高耐用

用於保護底座的
可更換型塑料底板
有助於機器在工作表面平滑滑動

