

Model No.LS1219L 305MM SLIDE COMPOUND MITER SAW

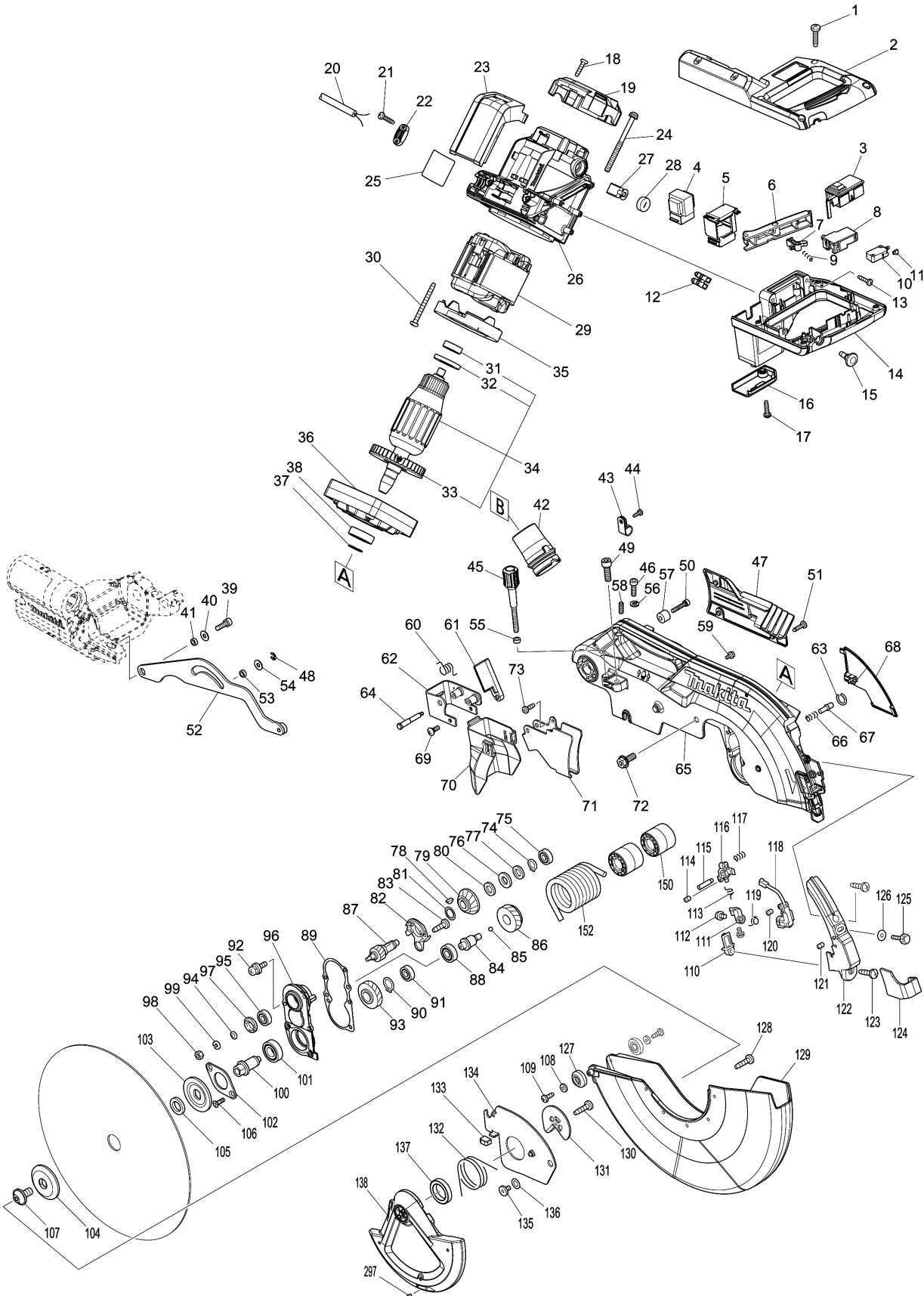

Model No.LS1219L 305MM SLIDE COMPOUND MITER SAW

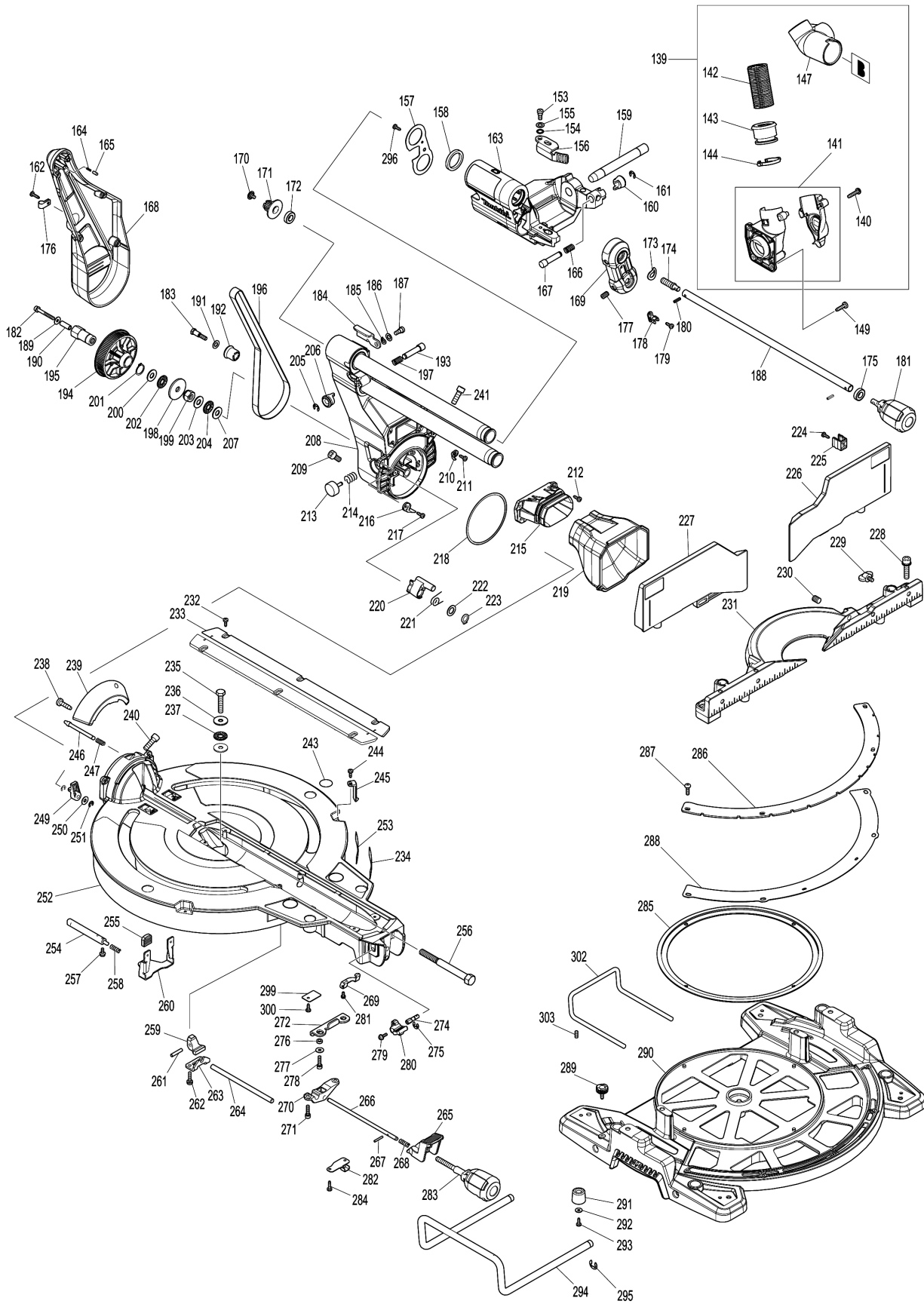

Model No.LS1219L 305MM SLIDE COMPOUND MITER SAW

分解圖號	零件編號	品名	交換	數量	New/Old	選擇1	選擇2	註記
001	265995-6	攻牙螺絲 4X18		6				
002	183H19-3	HANDLE SET		1				
C10	810486-8	注意標籤		1				
C20	808641-4	切換指示標籤		1				
D10		INC. 14						
003	638652-3	雷射開關裝置		1				
004	620723-0	POWER SUPPLY CIRCUIT		1				
005	451412-4	外殼		1				
006	451003-1	開關桿		1				
007	416356-5	鎖定槓 F/LF1000		1				
008	650687-4	開關TGC32B		1				
009	231026-3	彈簧 4		1				
013	265995-6	攻牙螺絲 4X18		4				
014	183H19-3	HANDLE SET		1				
C10	810486-8	注意標籤		1				
C20	808641-4	切換指示標籤		1				
D10		INC. 2						
015	451037-4	開關按鈕		1				
016	451000-7	引線蓋座		1				
017	265995-6	攻牙螺絲 4X18		1				
018	265995-6	攻牙螺絲 4X18		2				
019	457652-2	後蓋		1				
020	693564-7	電線 2.0-2-2.5		1				
021	265995-6	攻牙螺絲 4X18		2				
022	687149-9	電線固定片		1				
023	631863-9	控制器		1				
024	911948-0	螺絲M6X80		4				
025	854B49-2	LS1219L NAME PLATE		1				
026	144532-8	馬達外殼		1				
C10	643653-8	碳刷座 6.5-13.5		2				
027	181044-0	碳刷CB-153 C/A-81240		1				
028	643650-4	碳刷座蓋 6.5-13.5		2				
029	590026-5	外線圈110V		1				
C10	654020-2	碳刷座圈 CB-5		2				
C20	654502-4	連接頭 P-2		2				
030	266329-6	螺絲5X60		2				
031	210067-2	滾珠軸承 6000ZZ		1				
032	681642-5	絕緣墊圈		1				
033	240001-8	風葉80 F/LS1013,1212		1				
034	510159-0	馬達心110V		1				
D10		INC. 31-33						

Model No.LS1219L 305MM SLIDE COMPOUND MITER SAW

分解圖號	零件編號	品名	交換	數量	New/Old	選擇1	選擇2	註記
035	451194-8	導流板		1				
036	318471-0	馬達支架		1				
037	961057-5	檔圈 S-17		1				
038	210301-0	培林6003DDW		1				
039	922331-6	H.S.H.螺絲 M6X20		1				
040	253804-1	平墊片 6		1				
041-1	257461-7	RING 6		1				
042	457704-9	集塵噴頭		1	*			
042-1	459250-8	集塵接頭	S	1				
043	687049-3	保險片		1				
044	266034-5	螺絲 4X16		1				
045	251554-2	手擰螺絲M6 * 40		1				
046	922332-4	H.S.H.螺絲 M6X20		1				
047	458146-0	標識標牌		1				
048	961018-5	停止圈 E-5		1				
049	251547-9	螺栓 M8 * 25		1				
050	922251-4	六角承窩圓柱頭螺栓 M5X30		1				
051	266034-5	螺絲 4X16		3				
052-1	140J53-8	連結板組		1				
053-1	257461-7	RING 6		1				
054	253804-1	平墊片 6		1				
055-1	262190-9	URETHANE RING 5		1				
056	942151-2	彈性墊圈 6		1	*			
056-1	253428-3	彈簧墊圈 6	O	1				
057	257449-7	套筒 6		1				
058	266321-2	螺絲M6X16 F/LS0814FL		1				
059	911114-9	螺絲M4X10		2				
060-1	232412-1	扭力彈簧11		1				
061	457764-1	集塵板		1				
062	161647-6	防護座		1				
063	231928-3	彈簧 8		1				
064	251544-5	肩銷螺絲 M4		1				
065-1	140N08-7	BLADE CASE COMPLETE		1				
C10	263005-3	橡皮銷 6		3				
C20	810064-4	雷射光線警告標籤 F/LS0814FL		1				
C30	810354-5	LASER BEAM LABEL		1				
C40	807W91-8	CAUTION LABEL		1				
066	231240-1	扭力彈簧7		1				
067	256633-1	銷 6		1				
068	458148-6	導線罩		1				

Model No.LS1219L 305MM SLIDE COMPOUND MITER SAW

分解圖號	零件編號	品名	交換	數量	New/Old	選擇1	選擇2	註記
069	265028-7	+ PAN HEAD SCREW M4X11		1				
070	422235-7	護具		1				
071	347308-4	護板		1				
072	266283-4	外六角頭螺絲M8X20		1				
073	266020-6	自攻螺絲 4X12		1				
074	961052-5	擋圈 S-12		1				
075	210005-4	軸承 608DW		1				
076	261104-5	橡膠墊片12 F/MUM236		1				
077	253744-3	F 華士 12		1				
078	254001-2	半圓鍵		1				
079	227550-2	螺旋錐齒輪32		1				
080	253744-3	F 華士 12		1				
081	253313-0	薄墊片14 F/4340CT,50CT		1				
082	451002-3	軸座		1				
083	266026-4	自攻螺絲 CT 4X12		2				
084	325643-0	齒輪軸		1				
085-1	216049-2	STEEL BALL 4		1				
086	227702-5	減速齒輪27		1				
087	227701-7	斜齒輪14		1				
088	210067-2	滾珠軸承 6000ZZ		1				
089	442147-8	密封墊片		1				
090	961055-9	擋圈 S-15		1				
091	210005-4	軸承 608DW		1				
092	911223-4	螺絲 M5X16		3				
093	227703-3	減速齒輪28		1				
094	267010-2	平墊圈 5		1				
095	210005-4	軸承 608DW		1				
096	158957-0	軸承箱組		1				
C10	263002-9	橡皮銷 4		1				
097	285847-5	培林押14-23		1				
098	931202-6	六角螺母M5		1				
099	942101-7	彈性墊圈 5		1	*			
099-1	253427-5	彈簧墊圈5	○	1				
100	325644-8	主軸		1				
101	211236-8	軸承6002DDW		1				
102	285732-2	軸承保持器51		1				
103	224431-1	內法蘭53		1				
104	224432-9	外法蘭53		1				
105	257060-5	內環15.8 (外徑25.4→內徑15.8)		1				
106	265034-2	螺絲M5X16		2				

Model No.LS1219L 305MM SLIDE COMPOUND MITER SAW

分解圖號	零件編號	品名	交換	數量	New/Old	選擇1	選擇2	註記
107	266755-9	HEX.SOCKET HEAD BOLT M10X20		1				
108	941051-3	F 華士 4		2				
109	266020-6	自攻螺絲 4X12		2				
110	418104-8	鏡片 F/LS0814FL		1				
111	419378-4	滑塊B F/LS0814FL		1				
112	911003-8	螺絲 M3X6		2				
113	231664-1	扭力彈簧9 F/LS0814FL		1				
114	266318-1	螺絲 F/LS0814FL		1				
115	266306-8	螺絲M5 F/LS0814FL		1				
116	419379-2	滑塊C F/LS0814FL		1				
117	233471-8	扭力彈簧 F/LS0814FL		1				
118	638651-5	雷射組		1				
119	231664-1	扭力彈簧9 F/LS0814FL		1				
120	266318-1	螺絲 F/LS0814FL		1				
121	266229-0	六角螺母 M5-8		2				
122-1	458903-6	雷射蓋		1				
123	266034-5	螺絲 4X16		2				
124	457664-5	保護器		1				
125	265753-0	調整螺絲 F/LS0814FL		1				
126-1	267066-5	平墊片 5		1				
127	424193-3	滾輪		2				
128	266385-6	螺絲4X14		3				
129	458144-4	安全蓋 B		1				
130	266385-6	螺絲4X14		1				
131	347213-5	中心板		1				
132	231634-0	扭力彈簧45		1				
133	424190-9	墊子		1				
134	347214-3	中心蓋		1				
135	265985-9	螺母M6		1				
136	253932-2	華士10		1				
137	210168-6	球軸承 6805DDW		1				
138	458437-9	安全蓋 A		1				
139	126792-4	集塵頭組		1	*			
D10		INC. 140-144,147			*			
139-1	127274-9	集塵接頭組	S	1	*			
C10	458939-5	按鈕A	S	1	*			
C20	232485-4	壓縮彈簧5	S	1	*			
D10		INC. 140-144,147			*			
139-2	127274-9	集塵接頭組	O	1				
C10	458939-5	按鈕A		1				

Model No.LS1219L 305MM SLIDE COMPOUND MITER SAW

分解圖號	零件編號	品名	交換	數量	New/Old	選擇1	選擇2	註記
C20	232485-4	壓縮彈簧5		1				
D10		INC. 141-144,147						
140	265995-6	攻牙螺絲 4X18		3	*			
141	183H71-1	軟管連接器組		1	*			
141-1	413J67-3	HOSE CONNECTOR	S	1				
142	245048-7	軟管 28-0.5		1				
143	457672-6	SLEEVE		1				
144	457673-4	STOPPER		1				
147	458198-1	軟管		1	*			
147-1	459249-3	軟管接頭	S	1				
149	266034-5	螺絲 4X16		3				
150	458149-4	套筒 17		2				
152	233542-1	扭力彈簧40		1				
153	251267-5	螺絲M6		1				
154	253948-7	波形墊片8		1				
155	253835-0	平面墊片 8		1				
156	347221-6	制動臂		1				
157	347222-4	前臂板		1				
158	262076-7	毛氈環30 F/LS1013,1212		2				
159	326994-4	桿 16		1				
160	271437-0	鈕 22		1				
161	961013-5	停止圈 E-7		1				
162	266034-5	螺絲 4X16		4				
163	144912-8	前臂組		1				
C10	263005-3	橡皮銷 6		2				
164	233151-6	扭力彈簧4 F/4304T,4324		1				
165	256364-2	銷 4		1				
166	232384-0	壓縮彈簧 10		1				
167	326977-4	止動銷		1				
168	458145-2	臂蓋		1				
169	144658-6	座組		1				
C10	812X89-8	INDICATION LABEL		1				
170	265008-3	螺絲M5		1				
171	222191-9	滑輪 17-19.3		1				
172	210167-8	球軸承 6900LLB		1				
173	267804-5	波浪墊片15 F/HR2230		1				
174	326975-8	軸		1				
175	210167-8	球軸承 6900LLB		1				
176	687049-3	保險片		1				
177	913416-9	固定螺絲 M8 * 12		2				
178	416536-3	板手座 F/LS0811		1				

Model No.LS1219L 305MM SLIDE COMPOUND MITER SAW

分解圖號	零件編號	品名	交換	數量	New/Old	選擇1	選擇2	註記
179	266026-4	自攻螺絲 CT 4X12		1				
180	951107-4	彈簧銷 4-14 (F/6920N)		2				
181	273016-0	握把 50B		1				
182	266440-4	螺栓 M5X40		1				
183	251545-3	肩銷螺絲 M6		1				
184	144930-6	止動桿		1				
C10	812X87-2	INDICATION LABEL		1				
185	253948-7	波形墊片8		1				
186	253835-0	平面墊片 8		1				
187	251267-5	螺絲M6		1				
188	327054-5	銷 9-418		1				
189	253194-2	F 華士5		1				
190	257436-6	套筒 5		1				
191	253165-9	F 華士 8		1				
192	457666-1	套管 20		1				
193	326977-4	止動銷		1				
194	222192-7	滑輪 17-87.8		1				
195	327053-7	HEX 螺母 M10-19		1				
196	225102-3	同步帶15-810		1				
197	232384-0	壓縮彈簧 10		1				
198	253388-9	平墊圈 10		1				
199	252244-0	鎖定螺母 M10-17		1				
200	253024-7	平面墊片10		1				
201	961057-5	檔圈 S-17		1				
202	216413-7	針型培林 F/LS0814FL		1				
203	253024-7	平面墊片10		1				
204	216413-7	針型培林 F/LS0814FL		1				
205	961013-5	停止圈 E-7		1				
206	271437-0	鈕 22		1				
207	253024-7	平面墊片10		1				
208	144911-0	臂組		1				
C10	812X88-0	INDICATION LABEL		1				
209	251547-9	螺栓 M8 * 25		1				
210	458151-7	指示板		1				
211	266026-4	自攻螺絲 CT 4X12		1				
212	266034-5	螺絲 4X16		4				
213	415208-7	固定鈕 F/LS1211		1				
214	233031-6	彈簧 12 F/9027		1				
215	457654-8	集塵座		1				
216	458150-9	INDICATION PLATE L		1				
217	266026-4	自攻螺絲 CT 4X12		1				

Model No.LS1219L 305MM SLIDE COMPOUND MITER SAW

分解圖號	零件編號	品名	交換	數量	New/Old	選擇1	選擇2	註記
218	253389-7	墊片 94		1				
219	422229-2	集塵		1				
220	319593-9	塞子		1				
221	231646-3	扭力彈簧14 F/LS0811		1				
222	253744-3	F 華士 12		1				
223	961052-5	擋圈 S-12		1				
224	266026-4	自攻螺絲 CT 4X12		2				
225	457668-7	座		2				
226	144925-9	上層擋板 R F/LS1219		1				
C10	810503-4	注意標籤		1				
227	144922-5	上層擋板 L F/LS1219		1				
C10	810503-4	注意標籤		1				
228	922458-2	螺栓 M8X35		4				
229	251887-5	螺絲M6X10		2				
230	251561-5	連接頭螺栓 M10 * 12		2				
231	319565-4	導向擋		1				
232	266026-4	自攻螺絲 CT 4X12		6				
233	451201-7	刀口板		2				
235	265442-7	六角螺絲M8X40		1				
236	253852-0	F 華士 8		2				
237	216413-7	針型培林 F/LS0814FL		1				
238	266385-6	螺絲4X14		2				
239	458147-8	水平尺板		1				
240	251547-9	螺栓 M8 * 25		1				
241	251547-9	螺栓 M8 * 25		1				
243	813L22-1	CAUTION LABEL		2				
244	266026-4	自攻螺絲 CT 4X12		2				
245	457702-3	INDICATION PLATE		2				
246	326970-8	鎖銷 8		1				
247	234122-6	壓縮彈簧6		1				
249	457657-2	槓桿 25		1				
250	253804-1	平墊片 6		1				
251	961018-5	停止圈 E-5		2				
252	144928-3	轉動座組		1				
D10		INC. 243,253						
253	812X85-6	CAUTION LABEL		1				
254	326973-2	桿 12		1				
255	286039-9	帽		2				
256	326976-6	中心軸		1				
257	911113-1	盤頭螺絲 M4X10		2				
258	231325-3	彈簧 F/LS0811		1				

Model No.LS1219L 305MM SLIDE COMPOUND MITER SAW

分解圖號	零件編號	品名	交換	數量	New/Old	選擇1	選擇2	註記
259	310803-7	止轉器		1				
260	347217-7	槓桿板		1				
261	256186-0	插銷 5		1				
262	911231-5	螺絲 M5X20		2				
263	347219-3	止動架		1				
264	327052-9	鎖桿		1				
265	457656-4	鎖定桿		1				
266	327051-1	鎖定銷 6		1				
267	256158-5	插銷 3		1				
268	231325-3	彈簧 F/LS0811		1				
269	347237-1	凸輪盤		1				
270	319592-1	銷座		1				
271	922231-0	H.S.H.螺絲 M5X20		2				
272	347216-9	鎖板		1				
274	326972-4	桿 6		1				
275	961011-9	擋圈 E-4		1				
276	257425-1	環 5		2				
277	253194-2	F 華士5		2				
278	922231-0	H.S.H.螺絲 M5X20		2				
279	911113-1	盤頭螺絲 M4X10		1				
280	144656-0	桿 25		1				
C10	263005-3	橡皮銷 6		1				
281	911008-8	盤頭螺釘 M3 * 8		1				
282	345272-3	鎖定槓桿板 F/LS0814FL		1				
283	273015-2	握把 50A		1				
284	266026-4	自攻螺絲 CT 4X12		2				
285	457655-6	滑板		1				
286-1	347412-9	儀表刻度盤		1				
287	251546-1	+ PAN HEAD SCREW M5		4				
288	347218-5	儀表鎖緊板		1				
289	265786-5	螺絲 M5X16		2				
290	310891-4	底座		1	*			
290-1	310891-4	底座	○	1				
291	421845-7	腳		4				
292	267195-4	F 華士4		4				
293	266026-4	自攻螺絲 CT 4X12		4				
294	327095-1	座 200		2	*			
295	961015-1	擋圈 E-9		2				
296	266026-4	自攻螺絲 CT 4X12		1				
297	266318-1	螺絲 F/LS0814FL		1				
299	232249-6	鋼板彈簧		1				

Model No.LS1219L 305MM SLIDE COMPOUND MITER SAW

分解圖號	零件編號	品名	交換	數量	New/Old	選擇1	選擇2	註記
300	266026-4	自攻螺絲 CT 4X12		1				
302	327145-2	座		1				
303	266213-5	H.S.H螺絲		1				
304	232249-6	鋼板彈簧		1				
305	319815-7	輔助底座	S	2				
306	327315-3	桿12	S	4				
307	911113-1	盤頭螺絲 M4X10	S	4				
308	347509-4	輔助擋	S	2				
309	922443-5	螺絲M8X25 F/LS0814FL	S	4				
A01	122852-0	集塵袋總成		1				
C10	410602-8	集塵袋口蓋		1				
A02	126617-2	垂直式虎鉗組 F/LS1019		1				
D10		COMPO-PARTS						
A03	762001-3	三角規		1				
A04	B-67474	鎢鋼鋸片(新式刀 刃)305X25.4X100TX1.65 木 材、MDF板、層壓		1				
A05	781044-6	HEX. WRENCH 6		1				
A06	783208-8	六角板手 2.5 F/JN1601		1				

Please order the parts with part number.

Print Date 2022/3/11