

Model No.M6001 10MM DRILL

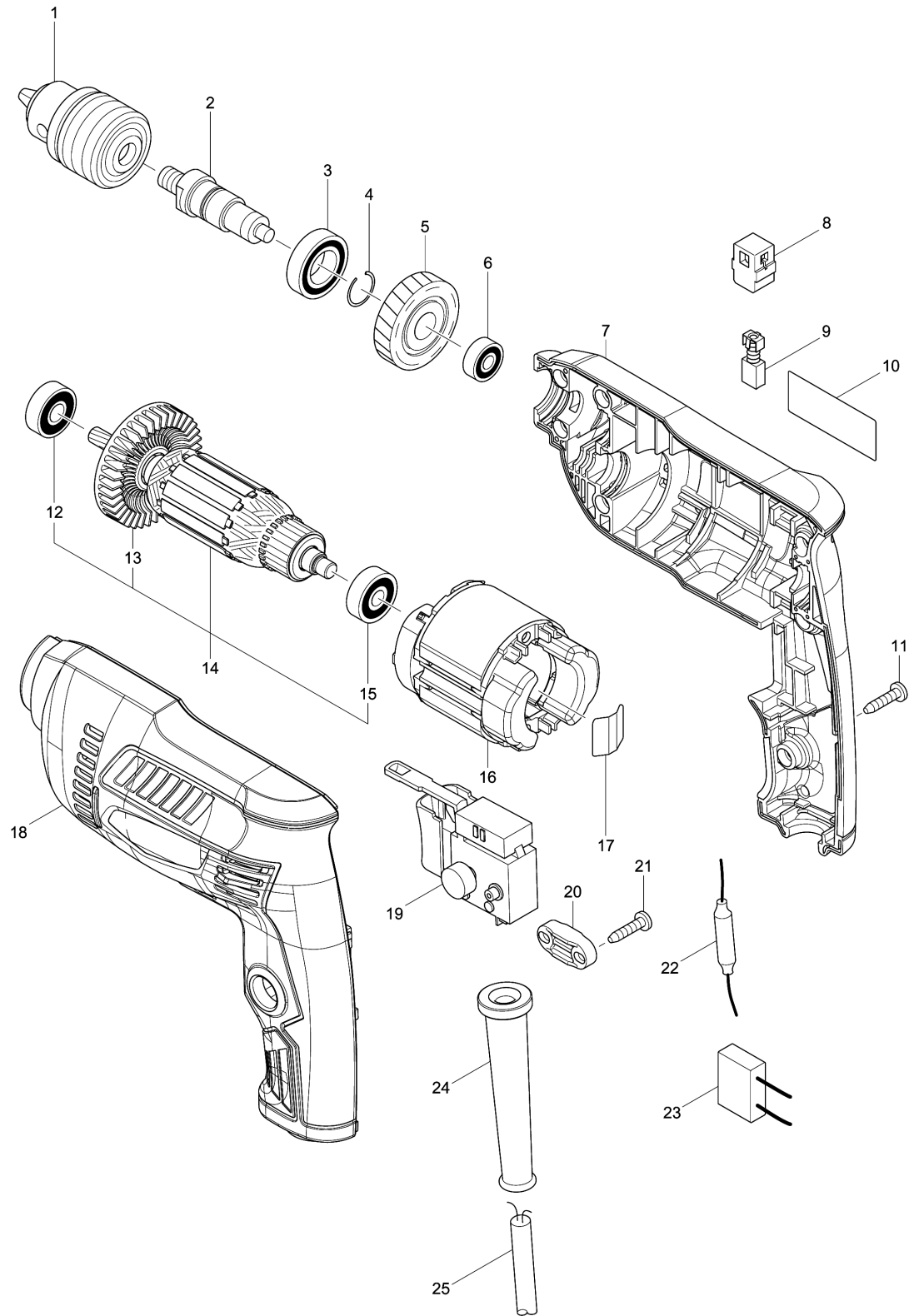

Model No.M6001 10MM DRILL

分解圖號	零件編號	品名	交換	數量	New/Old	選擇1	選擇2	註記
001	766014-6	夾頭S10		1				
002	324376-4	夾頭軸心 F/MT603		1				
003-1	210153-9	軸承 6902ZZ		1				
004	233925-5	彈簧圈13		1				
005	226578-7	螺旋齒輪35 F/MT603		1				
006-1	210137-7	培林 606ZZ		1				
007-1	183D43-2	HOUSING SET		1				
D10		INC. 18						
008	643563-9	碳刷座5X8 F/MT603,650,400		2				
009	191956-9	碳刷 CB-75		1				
010	850X24-8	M6001 NAME PLATE		1				
011	266326-2	螺絲 M4X18		7				
012-1	210046-0	培林 608ZZ		1				
013	240066-0	風葉52		1				
014	515846-6	馬達心110V F/MT606		1				
D10		INC. 12,13,15						
015-1	210050-9	培林 627ZZ		1				
016	639356-0	外線圈110V		1				
017	232210-3	彈簧片 F/MT603,650		1				
018-1	183D43-2	HOUSING SET		1				
D10		INC. 7						
019	650552-7	啟向變速開關		1				
020	687124-5	電線固定片		1				
021	266326-2	螺絲 M4X18		2				
022	646147-2	防磁波線圈		1				
023	645190-8	噪音防止器		1				
024	682569-2	電線保護管		1	*			
024-1	682582-0	CORD GUARD	S	1				
025	693354-8	電線 0.75-2-2.0		1				
A01	763447-6	夾頭扳手S10		1				
A02	418163-2	夾頭板手套 10		1	*			

Please order the parts with part number.

Print Date 2022/2/23