

Model No.M9800 MULTI TOOL

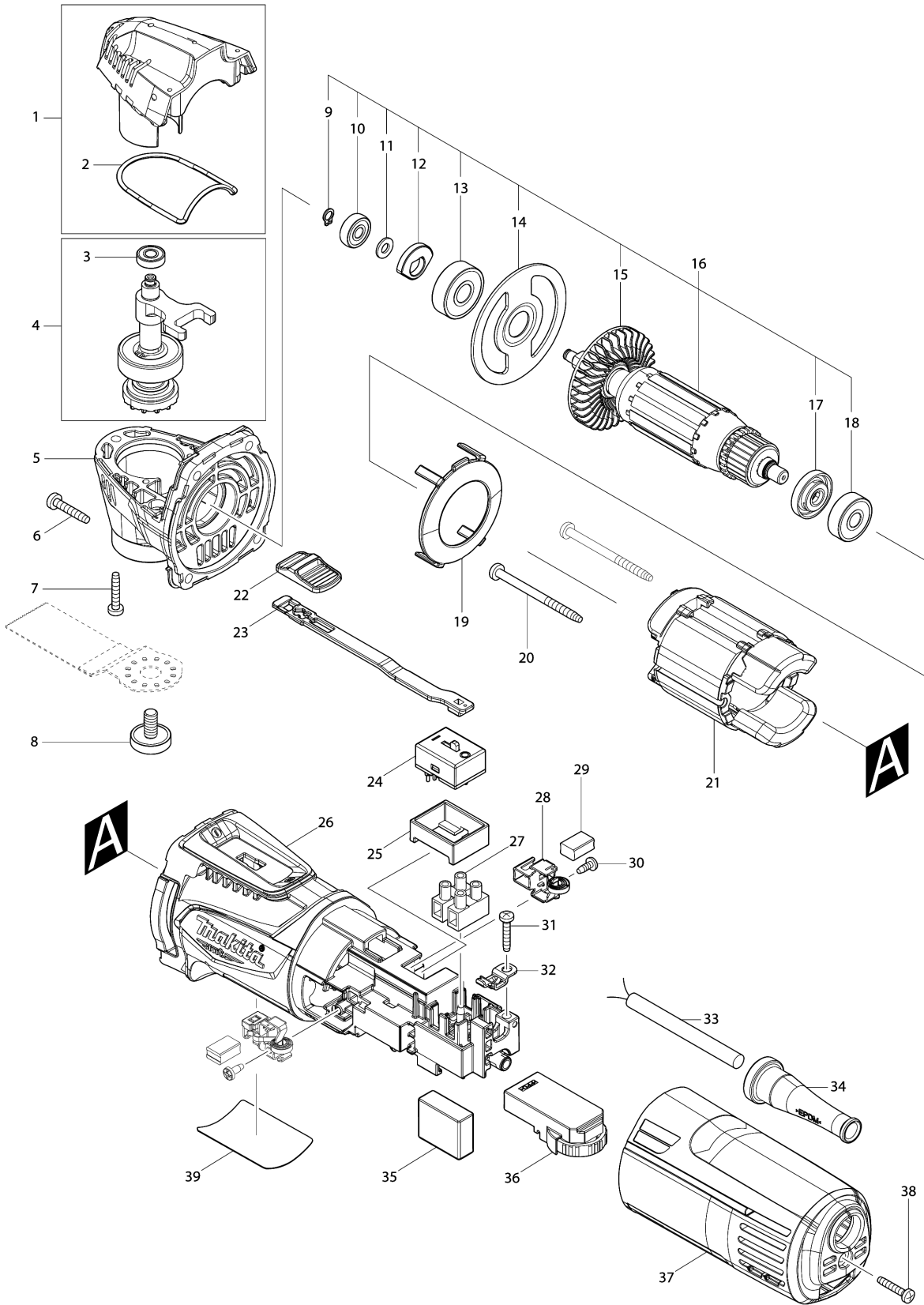

Model No.M9800 MULTI TOOL

分解圖號	零件編號	品名	交換	數量	New/Old	選擇1	選擇2	註記
001	183M17-7	頭部外殼組		1				
	D10	INC. 2,5						
002	422371-9	SEAL RING		1				
003	210039-7	軸承 F/BGA402R		1				
004	136108-5	主軸組件		1				
	D10	INC. 3						
005	183M17-7	頭部外殼組		1				
	D10	INC. 1,2						
006	266424-2	攻牙螺絲 4X20		4				
007	266424-2	攻牙螺絲 4X20		3				
008	265674-6	內六角螺栓 M6X14		1				
009	961008-8	RETAINING RING S-5		1				
010	210144-0	球面軸承 505		1				
011	267010-2	平墊圈 5		1				
012	313245-4	平衡裝置		1				
013	211092-6	培林 629DDW		1				
014	285034-6	BEARING RETAINER		1				
015	240195-9	FAN 50		1				
016	515441-2	馬達心110V		1				
	D10	INC. 9-15,17,18						
017	681636-0	絕緣華士		1				
018	210045-2	滾珠軸承 627DDW		1				
019	458915-9	擋板		1				
020	266415-3	螺絲 4X55		2				
021	634721-8	外線圈110V		1				
022	453761-5	開關板		1				
023	458914-1	開關槓桿		1				
024	651388-7	開關 ASW-1108-03		1				
025	424860-0	開關蓋		1				
026	458949-2	MOTOR HOUSING		1				
027	654531-7	線端裝置 F/TW1000		1				
028	643716-0	碳刷架		2				
029	194721-5	碳刷 CB-458		1				
030	266492-5	螺絲 3X8		2				
031	266424-2	攻牙螺絲 4X20		1				
032	687681-3	STRAIN RELIEF		1				
033	693354-8	電線 0.75-2-2.0		1				
034	682096-9	CORD GUARD		1				
035	632N44-2	電容器元件		1				
	C11	地線		1				
036	620A78-9	控制器		1				

Model No.M9800 MULTI TOOL

分解圖號	零件編號	品名	交換	數量	New/Old	選擇1	選擇2	註記
037	458953-1	REAR COVER		1				
038	266424-2	攻牙螺絲 4X20		1				
039	855P47-3	M9800 NAME PLATE		1				
A01	410047-0	板手座 5.6		1				
A02	783203-8	六角板手 5		1				
A03B	B-21624	三角形砂紙 木工 60/10		1				
A04B	B-21630	三角形砂紙 木材 80/10		1				
A05B	B-21646	三角形砂紙 木材 120/10		1				
A06B	B-65115	STARLOCK三角形砂紙墊(魔鬼氈) (TMA078)		1				
A07B	B-64814	STARLOCK直切鋸片32 (TMA047)-木材及金屬		1				
A08B	B-65040	STARLOCK超硬半圓鋸片 65 (TMA071)-清除牆壁磁磚較薄的接縫		1				
A09B	821764-1	PLASTIC CASE		1				
C10	452432-1	SLIDE LATCH		2				
A10B	819G30-0	M9800BKX2 PLASTIC CASE LABEL		2				

Please order the parts with part number.

Print Date 2021/12/3