

Model No.M8103 13MM HAMMER DRILL

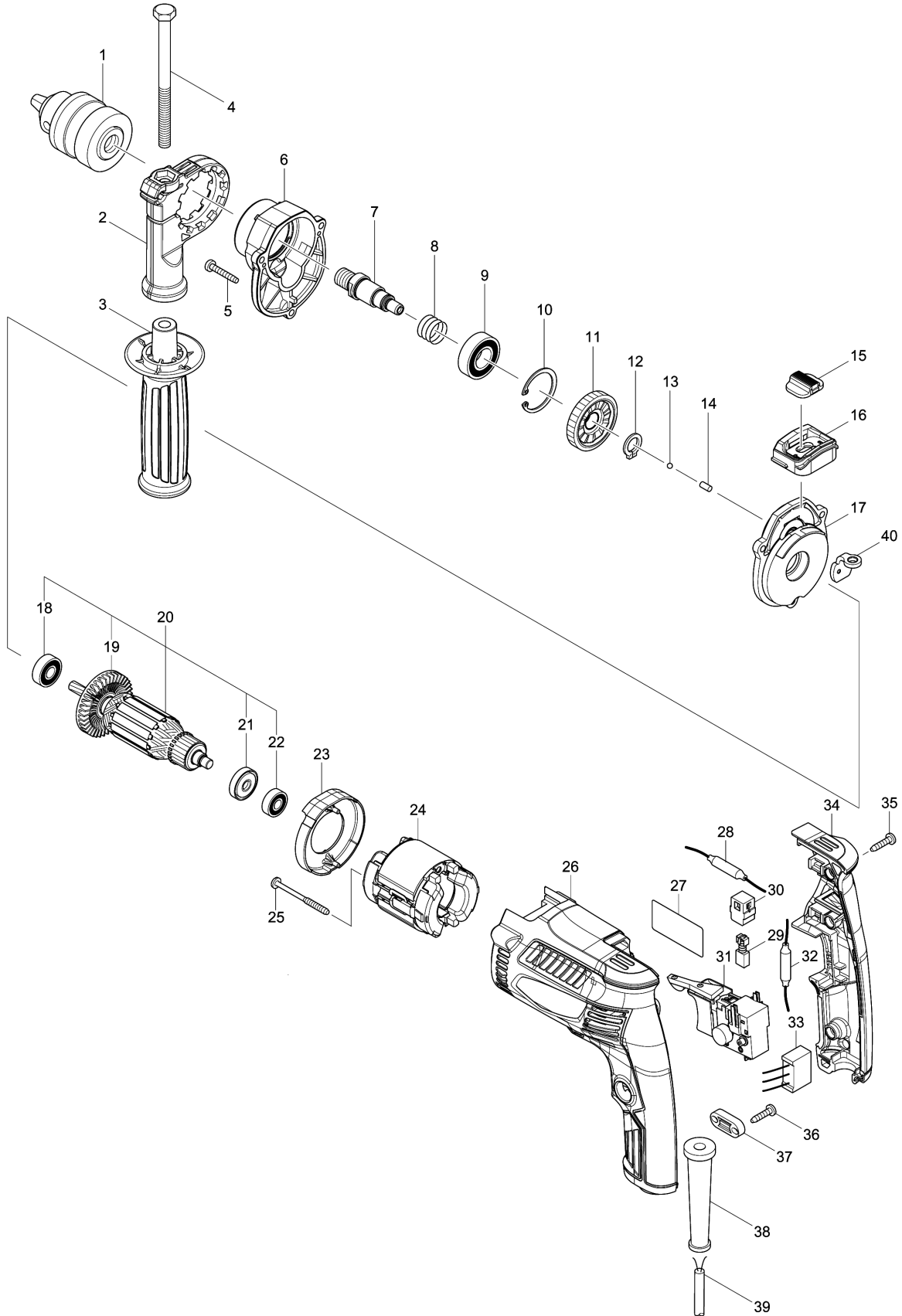

Model No.M8103 13MM HAMMER DRILL

分解圖號	零件編號	品名	交換	數量	New/Old	選擇1	選擇2	註記
001-1	763232-7	夾頭 S13		1				
002	454126-4	把手座		1				
003	142083-5	把手頭 36		1				
004	265495-6	螺絲 M8X110		1				
005	266374-1	螺絲 4X25		3				
006	454115-9	曲輪箱		1				
007-1	327325-0	軸心		1				
008	233330-6	扭力彈簧 16		1				
009-1	211484-9	軸承 6002LLB		1				
010	962151-6	擋圈 R-32		1				
011	227761-9	螺旋齒輪 37		1				
012	961052-5	擋圈 S-12		1				
013	216001-0	鋼珠 3.5		1				
014	256251-5	銷 4		1				
015	417819-4	切換板		1				
016	456511-7	LEVER CASE		1				
017-1	140K24-1	CAM HOUSING COMPLETE		1				
C11	140K25-9	CAM COMPLETE		1				
018	210005-4	軸承 608DW		1				
019	240055-5	風葉 48		1				
020	515866-0	馬達心 115V		1				
D10		INC. 18,19,21,22						
021	681652-2	絕緣華司		1				
022-1	211382-7	軸承 607ZZ		1				
023	456129-4	擋板		1				
024	593800-0	外線圈		1				
C10	654228-8	連接座		1				
025	266467-4	自攻螺絲 4X50		2				
026	456507-8	MOTOR HOUSING		1				
027	852B10-3	M8103 NAME PLATE		1				
028	646148-0	防磁波線圈		1				
029	191956-9	碳刷 CB-75		1				
030	643566-3	碳刷座 5X8		2				
031	650554-3	啟動開關		1				
032	646147-2	防磁波線圈		1				
033	645190-8	噪音防止器		1				
034	456510-9	HANDLE COVER		1				
035	266326-2	螺絲 M4X18		3				
036	266326-2	螺絲 M4X18		2				
037	687124-5	電線固定片		1	*			
037-1	687140-7	STRAIN RELIEF	S	1				

Model No.M8103 13MM HAMMER DRILL

分解圖號	零件編號	品名	交換	數量	New/Old	選擇1	選擇2	註記
038	682569-2	電線保護管		1	*			
038-1	682504-0	CORD GUARD 10-85	S	1				
039-2	693354-8	電線 0.75-2-2.0		1	*			
039-3	693454-4	POWER SUPPLY CORD 0.75-2-2.0	S	1				
040	345836-3	切換板		1				
A01	418163-2	夾頭板手套 10		1				
A02-1	763235-1	夾頭板手 S13		1				
A04A	821665-3	PLASTIC CARRYING CASE		1				
C10	452432-1	SLIDE LATCH		2				
C20	806G57-9	MAKITA MT LOGO LABEL		1				
A04B	821823-1	PLASTIC CASE		1				
C10	452143-8	軸心		2				
C20	452432-1	SLIDE LATCH		2				
C30	806G57-9	MAKITA MT LOGO LABEL		1				
A05A	8032T9-1	M8103KX1B PLASTIC CASE LABEL		2				
A05B	8026J9-2	M8103KX2B PLASTIC CASE LABEL		2				
A06A	D-71962	DRILL BIT 9PCS SET		1				
A06B	D-70194	26PCS.ACCESSORY SET		1				

Please order the parts with part number.

Print Date 2022/2/11