

Model No.M4100 110MM CUTTER

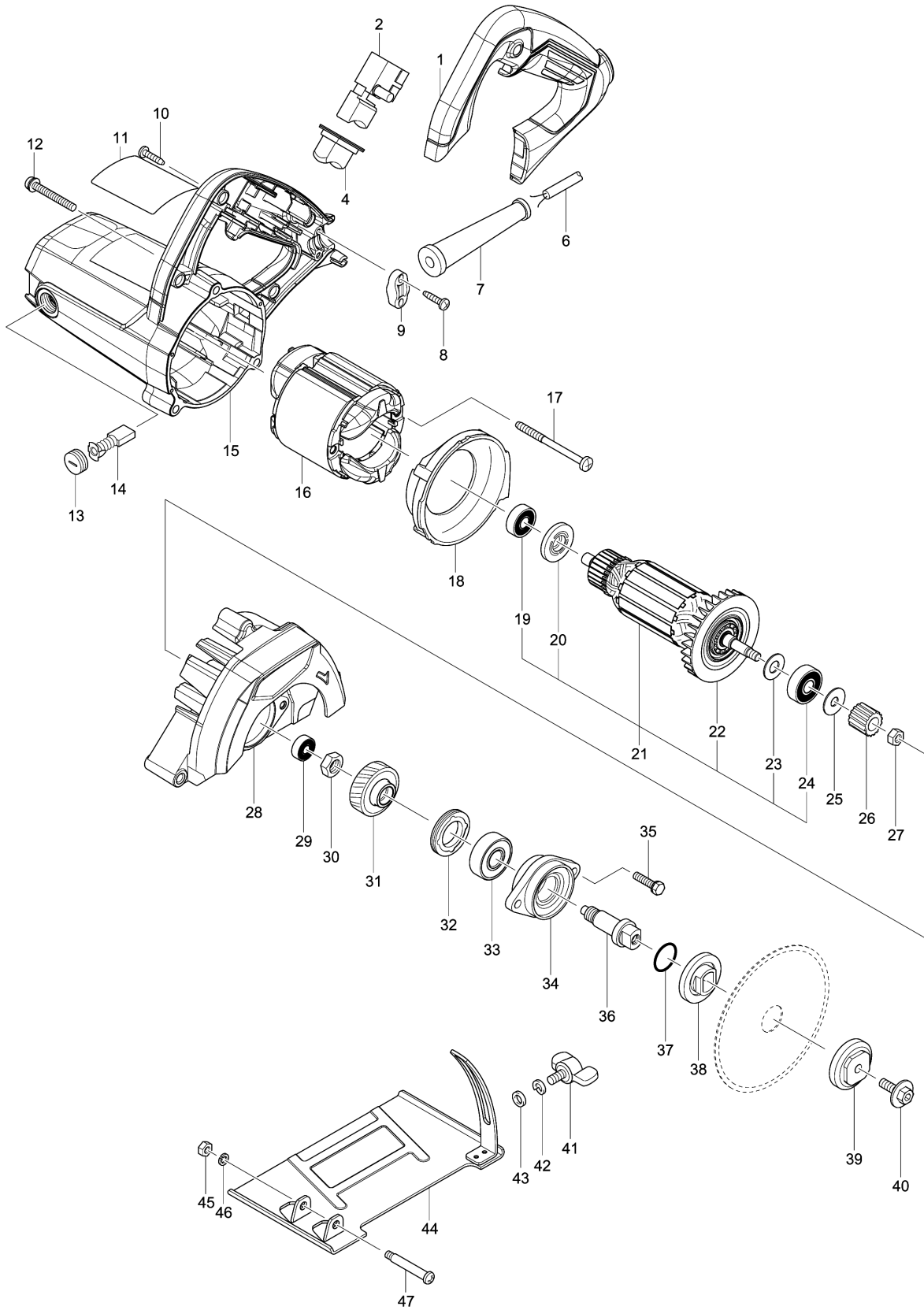

Model No.M4100 110MM CUTTER

分解圖號	零件編號	品名	交換	數量	New/Old	選擇1	選擇2	註記
001	456488-6	HANDLE COVER		1				
002	650239-1	啟動開關		1				
004	421812-2	防塵蓋		1				
006	693554-0	電線 2.0-2-2.0		1				
007	682575-7	電線保護套		1				
008	266326-2	螺絲 M4X18		2				
009	687149-9	電線固定片		1				
010	266326-2	螺絲 M4X18		4				
011	852G81-0	M4100 NAME PLATE		1				
012	265104-7	螺絲M4X40 F/MT41,56,58		3				
013-1	643750-0	碳刷座蓋		2				
014	191963-2	碳刷CB-303 C/A-81664		1				
015	143584-6	MOTOR HOUSING COMPLETE		1				
C10	644501-4	碳刷座 5X11		2				
016	593966-6	外線圈110V		1				
C10	654020-2	碳刷座圈 CB-5		2				
C20	654485-8	PARALLEL SPLICE		2				
017	266352-1	螺絲 5X65		2				
018	417810-2	風葉座 F/MT410		1				
019	210046-0	培林 608ZZ		1				
020	681644-1	絕緣墊片		1				
021	513871-1	馬達心110V		1				
D10		INC. 19,20,22-24						
022	240053-9	風葉65 F/MT410		1				
023	267237-4	平面墊圈 9		1				
024	210125-4	培林 629DDW		1				
025	267239-0	平面墊圈 9		1				
026	226552-5	螺旋齒輪15 F/MT410,411		1				
027	252186-8	六角螺母 M6		1				
028	143583-8	BLADE CASE COMPLETE		1				
C10	263002-9	橡皮銷 4		1				
029	210137-7	培林 606ZZ		1				
030	252170-3	六角螺母M10-17 F/MT410,411		1				
031	227767-7	斜齒輪34		1				
032	285840-9	軸承保持環19-33 F/MT		1				
033	211145-1	軸承 6201ZZ		1				
034	317550-1	軸承箱 F/MT410,411		1				
035	265497-2	六角螺絲M5X20		2				
036	324221-3	軸心桿 F/MT410,411		1				

Model No.M4100 110MM CUTTER

分解圖號	零件編號	品名	交換	數量	New/Old	選擇1	選擇2	註記
037	213279-6	圈 18		1				
038	224080-4	內法蘭士 36		1				
039	224081-2	外法蘭士 36		1				
040	266510-9	六角螺絲 M6X18		1				
041	265754-8	蝶螺絲 M6X12		1				
043	941151-9	平面墊圈 6		1				
044	165711-5	底座		1				
045	252137-1	螺絲 M5X8		1				
046-1	253427-5	彈簧墊圈5		1				
047	265056-2	十字螺絲M5		1				
A01	781041-2	板手22 F/MT413		1				
A02	783217-7	六角板手 5		1				
A03	196432-8	供水管組		1				
C10	265099-4	螺絲 M4X14		1				
C20	412088-2	管 5		1				
C30	421835-0	供水插頭		1				
E03	645190-8	噪音防止器		1				

Please order the parts with part number.

Print Date 2022/2/11