

Model No.M3701 TRIMMER

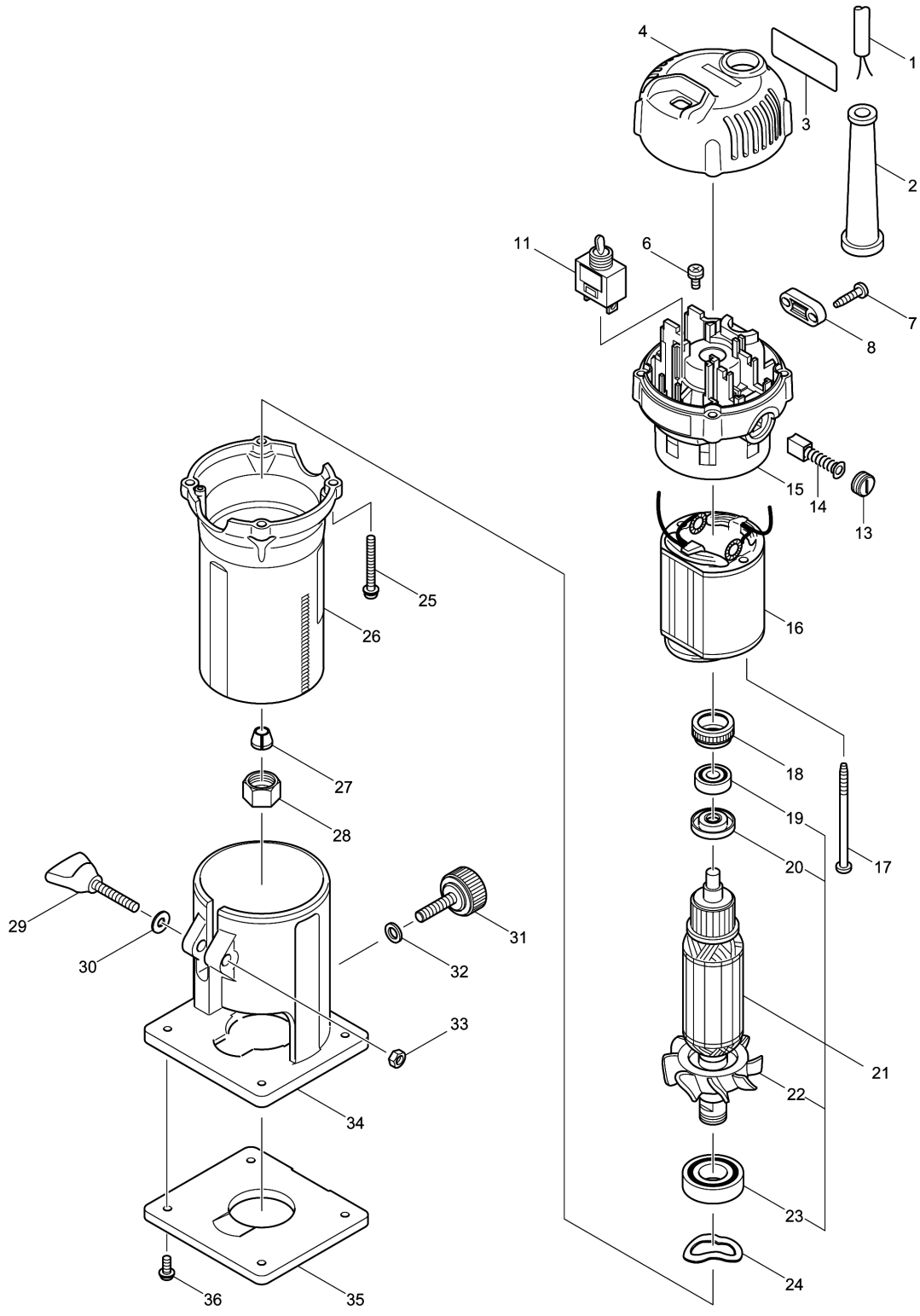

Model No.M3701 TRIMMER

分解圖號	零件編號	品名	交換	數量	New/Old	選擇1	選擇2	註記
001	693662-7	POWER SUPPLY CORD 0.75-3-2.0		1				
002	682504-0	電線保護管 10-85		1				
003	853R15-2	M3701 NAME PLATE		1				
004	458112-7	TOP COVER		1				
006	652014-1	螺絲M4X8		1				
007	266326-2	螺絲 M4X18		2				
008	687140-7	電線固定片		1				
011	651424-9	啟動開關		1				
013	643987-9	碳刷座蓋 5-8		2				
014	191938-1	碳刷CB-408		1				
015-1	140X51-6	BRACKET COMPLETE		1				
C10	643455-2	碳刷座 F/TW0200,MT958		2				
016-1	593970-5	FIELD ASSY 100-115V		1				
C10	654450-7	碳刷座圈		2				
C21	654485-8	PARALLEL SPLICE		2				
017	266340-8	螺絲 4X65		2				
018	421868-5	橡膠環 19		1				
019	210062-2	軸承 607ZZ		1				
020-1	681636-0	絕緣華士		1				
021	510266-9	馬達心110V		1				
D10		INC. 19,20,22,23						
022	241667-7	風葉 52		1				
023	211247-3	軸承 6002DW		1				
024	267785-3	波浪墊片 23		1				
025-2	266351-3	螺絲 4X35		4				
026	153851-1	馬達座 F/MT370		1	*			
026-1	153851-1	馬達座 F/MT370	<	1				
027	763662-2	夾子套管 6mm F/MT370		1				
028	763661-4	夾子螺母 6mm F/MT370		1				
029-1	251867-1	螺絲 M5X30 F/3701		1				
030	941101-4	F 華士 5		1				
031	265763-7	螺絲 M6X25		1				
032	941151-9	平面墊圈 6		1				
033-1	252156-7	螺母M5X8		1				
034	411930-4	底盤 F/3701		1				
035	410585-2	底盤連接器		1				
036	265142-9	螺絲 M4X10		4				
A01	122703-7	修邊導具組 F/接在122238-8 上		1				
C10	251471-6	平頭螺絲 L5		1				

Model No.M3701 TRIMMER

分解圖號	零件編號	品名	交換	數量	New/Old	選擇1	選擇2	註記
C20	265135-6	螺絲 M4X10		1				
C30	265763-7	螺絲 M6X25		1				
C40	265764-5	螺絲 M6		1				
C50	317788-8	導具固定座		1				
C60	324378-0	滾輪 11		1				
C71	341136-9	鈎		1				
C80	941151-9	平面墊圈 6		1				
A02	122704-5	直線導具組		1				
C10	252649-4	蝶螺母 M6		1				
C20	266339-3	螺絲 M6X20		1				
C31	343593-7	導具面板		1				
A03-1	343577-5	樣規導具 10mm		1				
A04	781036-5	板手 10		1				
A05	781037-3	板手 17		1				
A06	418647-0	切削轉扣板		1				
A07	733239-7	修邊刀刃6MM F/MT370		1	*			
A07-1	191Y83-2	STRAIGHT BIT 6 SET	○	1				
E01	645240-9	噪音防止器		1				
E02	646358-9	LINE COIL		1				

Please order the parts with part number.

Print Date 2022/2/11