

Model No.M2401 355MM PORTABLE CUT OFF

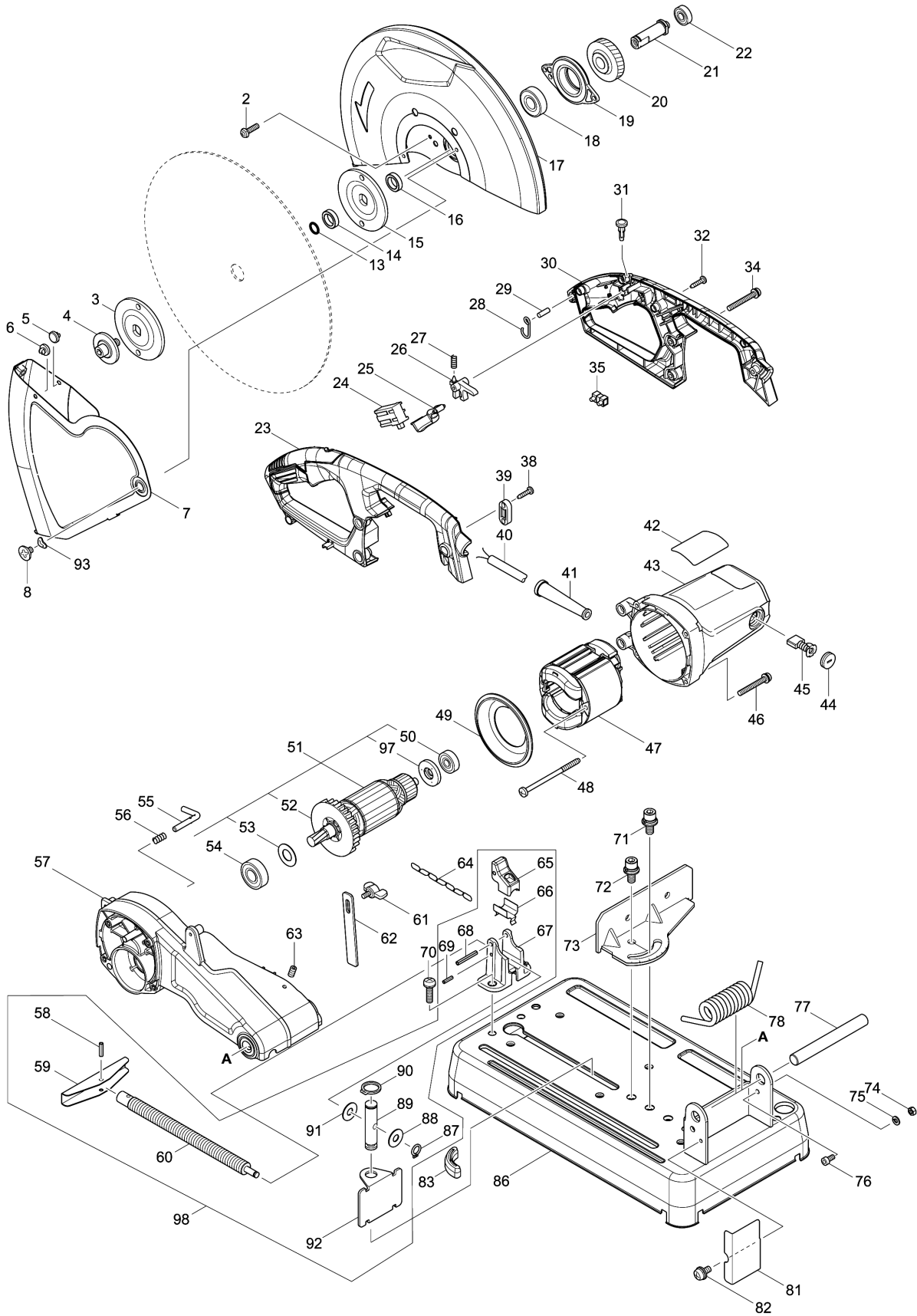

Model No.M2401 355MM PORTABLE CUT OFF

分解圖號	零件編號	品名	交換	數量	New/Old	選擇1	選擇2	註記
002	265122-5	螺絲M5X25 F/MT190,240		4				
003	224299-5	法蘭士90 F/2414B,NB		1				
004	251498-6	六角螺栓M10X25		1				
005	416771-3	栓 F/2416S		1				
006	416771-3	栓 F/2416S		1				
007	161529-2	安全護蓋		1				
008	265121-7	螺絲 M6		1				
013	213180-5	圈14 F/MT240		1				
014	257255-0	環17 F/MT240		1				
015	224299-5	法蘭士90 F/2414B,NB		1				
016	257255-0	環17 F/MT240		1				
017	140Y49-9	SAFETY COVER COMPLETE		1				
C10	807V73-4	CAUTION LABEL		1				
018	210155-5	球軸承6203ZZ		1				
019	316527-3	培林座 F/2414B,NB		1				
020	221462-1	螺旋齒輪43		1				
021	326790-0	主軸		1	*			
021-1	322633-4	車心 F/2414B,NB	○	1				
022-1	210199-5	BALL BEARING 6000ZZ		1				
023	183E50-1	HANDLE SET		1				
D10		INC. 30						
024	651067-7	開關		1				
025	418141-2	開關桿 F/MT240		1				
026	418139-9	開關固定桿 F/MT240		1				
027	231397-8	彈簧 4		1				
028	281216-8	鉤 F/MT240		1				
029	268101-2	銷6 F/MT240		1				
030	183E50-1	HANDLE SET		1				
D10		INC. 23						
031	418138-1	開關鈕 F/MT240		1				
032	266841-6	自攻螺絲4X18		4	*			
032-1	266326-2	螺絲 M4X18	○	4				
034	265104-7	螺絲M4X40 F/MT41,56,58		3				
038	266841-6	自攻螺絲4X18		2	*			
038-1	266326-2	螺絲 M4X18	○	2				
039	687149-9	電線固定片		1				
040-1	693564-7	電線 2.0-2-2.5		1				
041	682575-7	電線保護套		1				
042	852N80-4	M2401 NAME PLATE		1				

Model No.M2401 355MM PORTABLE CUT OFF

分解圖號	零件編號	品名	交換	數量	New/Old	選擇1	選擇2	註記
043	144055-6	MOTOR HOUSING COMPLETE		1	*			
043-1	140X63-9	MOTOR HOUSING COMPLETE	○	1				
044	644802-0	碳刷蓋		2				
045	191953-5	碳刷CB-203		1				
046	265104-7	螺絲M4X40 F/MT41,56,58		4				
047	593946-2	外線圈110V		1	*			
047-1	593946-2	外線圈110V	○	1				
048	266328-8	螺絲 5X80		2				
049	418143-8	風葉座 F/MT240		1				
050	210070-3	軸承 6200ZZ		1				
051	513491-1	馬達心110V		1				
D10		INC. 50,52-54,97						
052	240003-4	風葉 80		1				
053	267274-8	墊片15		1				
054	210156-3	球軸承6202ZZ		1				
055	322665-1	制動器 F/2414B,NB		1				
056	233372-0	扭力彈簧7 F/MT240		1				
057	144057-2	齒輪箱		1				
C10	263029-9	橡皮銷6 F/MT240		1	*			
C11	263005-3	橡皮銷 6	○	1				
058	951163-4	彈簧銷5-20		1				
059	271431-2	手柄120		1				
060	326802-9	台鉗螺桿		1				
061	265754-8	蝶螺絲 M6X12		1				
062	347084-0	止動板		1				
063	251961-9	六角承窩固定螺絲(平端)M6X1		2				
064	282015-1	鏈條 F/MT240		1				
065	313114-9	虎鉗螺母 F/MT240		1				
066	347083-2	盤		1				
067	319474-7	螺桿導軌		1				
068	951175-7	彈簧銷5-36		1				
069	951110-5	彈簧銷4-16 F/MT240		1				
070	265125-9	螺絲M8X30 F/MT240		2				
071	251499-4	螺栓 M10X25		1				
072	251499-4	螺栓 M10X25		1				
073	345315-1	角度導板 F/MT240		1				
074	931302-2	六角螺母 M6		1				
075-1	253428-3	彈簧墊圈 6		1				
076	922312-0	H.S.H.螺絲 M6X12		1				

Model No.M2401 355MM PORTABLE CUT OFF

分解圖號	零件編號	品名	交換	數量	New/Old	選擇1	選擇2	註記
077	326801-1	桿16		1				
078	232325-6	扭力彈簧20		1				
081	345313-5	火花擋板 F/MT240		1				
082	265144-5	平頭螺絲M6X12		1				
083	421834-2	避震墊套 F/MT240		3				
086	161528-4	底座		1				
087	961004-6	擋圈 S-8		1				
088	267257-8	平面墊片8 F/MT240		1				
089-1	256474-5	連接銷10-16 F/MT240		1				
090	961056-7	保持圈S16 F/MT240		1				
091	267257-8	平面墊片8 F/MT240		1				
092	347085-8	虎鉗板		1				
093	253903-9	波形墊片6 F/MT240		1				
097	681630-2	絕緣華士		1				
098	135841-6	虎鉗組		1				
D10		INC. 58-60,65-69,87-92						
A01	783023-0	扳手8		1				

Please order the parts with part number.

Print Date 2021/12/3