

Model No.M1902 82MM PLANER

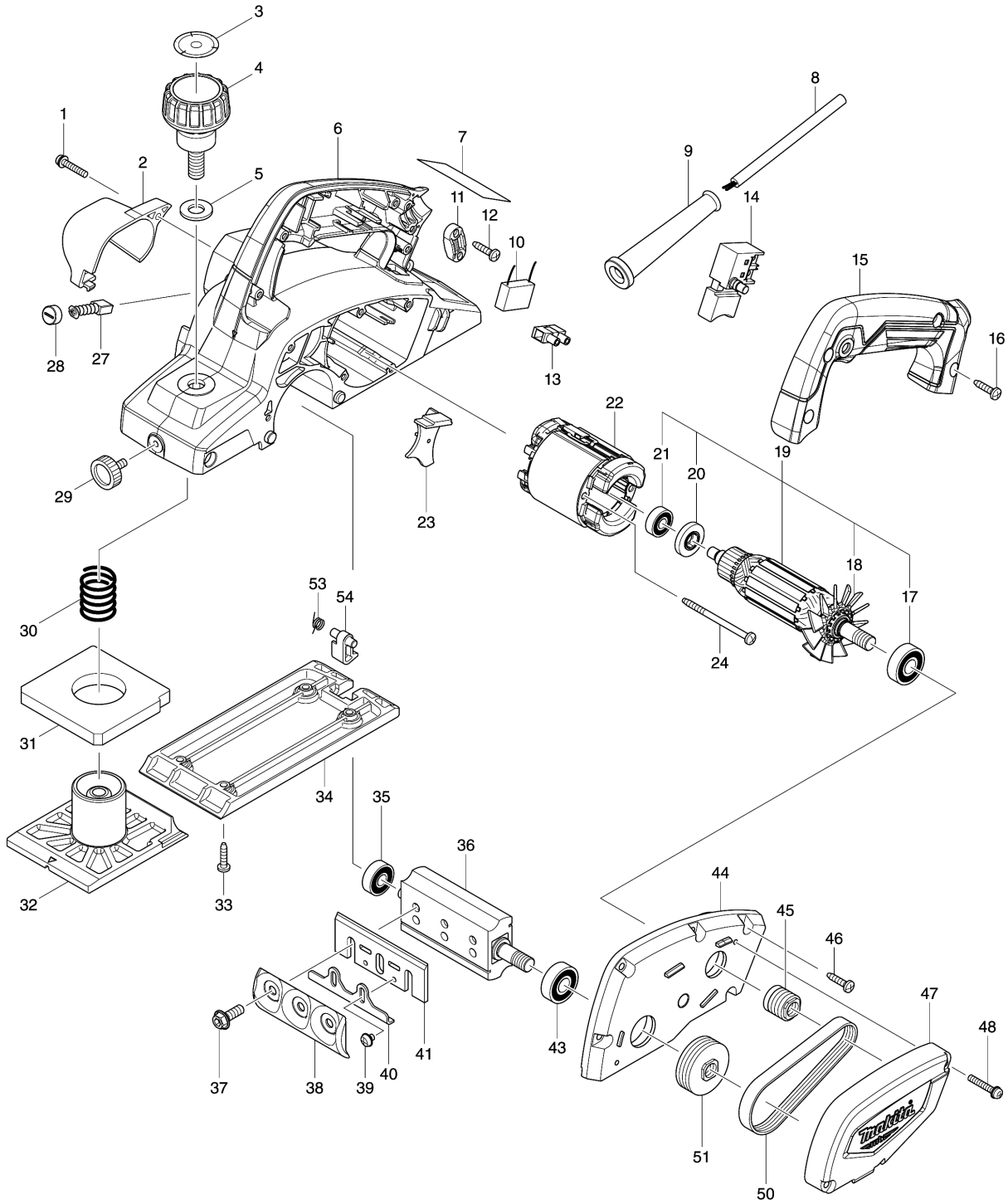

Model No.M1902 82MM PLANER

分解圖號	零件編號	品名	交換	數量	New/Old	選擇1	選擇2	註記
001	265147-9	螺絲M4X22 F/MT958		1				
002	456708-8	CHIP COVER		1				
003	809N37-6	SCALE LABEL		1				
004	271429-9	KNOB 44		1				
005	267278-0	平面墊片10 F/MT190		1				
006-1	140A25-9	MAIN FRAME COMPLETE		1				
C11	643858-0	碳刷座 6x9		2				
007	852K30-1	M1902 NAME PLATE		1				
008	693454-4	電線 0.75-2-2.0		1				
009	682504-0	電線保護管 10-85		1				
010	645190-8	噪音防止器		1				
011	687140-7	電線固定片		1				
012	266841-6	自攻螺絲4X18		2				
014	650246-4	啟動開關		1				
015	456705-4	HANDLE COVER		1				
016	266841-6	自攻螺絲4X18		4				
017	210141-6	BALL BEARING 6000DDW		1				
018	240068-6	風葉52 F/MT190		1				
019	513475-9	馬達心110V		1				
D10		INC. 17,18,20,21						
020	681672-6	絕緣華司		1				
021	211382-7	軸承 607ZZ		1				
022-1	599101-4	外線圈110V		1				
C10	654450-7	碳刷座圈		2				
C21	654485-8	PARALLEL SPLICE		2				
023	456707-0	ASSIST FAN GUIDE		1				
024	266334-3	螺絲4X60 F/HR2460,2MT190		2				
027	191938-1	碳刷CB-408		1				
028	643987-9	碳刷座蓋 5-8		2				
029	265757-2	圓柄螺絲M5X10 F/MT190		1				
030	233395-8	彈簧18 F/MT190		1				
031	421858-8	橡皮墊 F/MT190		1				
032	319418-7	FRONT BASE		1				
033	266841-6	自攻螺絲4X18		4				
034-1	319582-4	底座		1				
035	210046-0	培林 608ZZ		1				
036	161458-9	DRUM		1				
037	251482-1	HEX. SOCKET HEX. BOLT M6X17		6				
038	347024-8	DRUM PLATE		2				

Model No.M1902 82MM PLANER

分解圖號	零件編號	品名	交換	數量	New/Old	選擇1	選擇2	註記
039	265132-2	螺絲M4X5		4				
040	345644-2	調整板		2				
041	D-67228	HSS PLANER BLADE 82MM		1				
043	210141-6	BALL BEARING 6000DDW		1				
044	143763-6	BRACKET COMPLETE		1				
C10	263002-9	橡皮銷 4		2				
045	222163-4	皮帶輪4-20L F/MT190		1				
046	266841-6	自攻螺絲4X18		6				
047	456963-2	BELT COVER		1				
048	265101-3	螺絲M4X25 F/MT_SYS		2				
050	225092-0	皮帶 4-241		1				
051	222164-2	皮帶輪4-37 F/MT190		1				
053	231698-4	彈簧 7		1				
054	451392-4	腳		1				
A01	165378-9	導規 F/MT190		1				
A02	456751-7	BLADE GAUGE		1				
A03	783217-7	六角板手 5		1				
A04	122694-2	磨刀座 F/MT190		1				
C10	252649-4	蝶螺母 M6		2				
C20	266332-7	RH 方形頸螺栓 M6x35		2				

Please order the parts with part number.

Print Date 2021/12/3