

# Model No.M0920 180MM ANGLE GRINDER

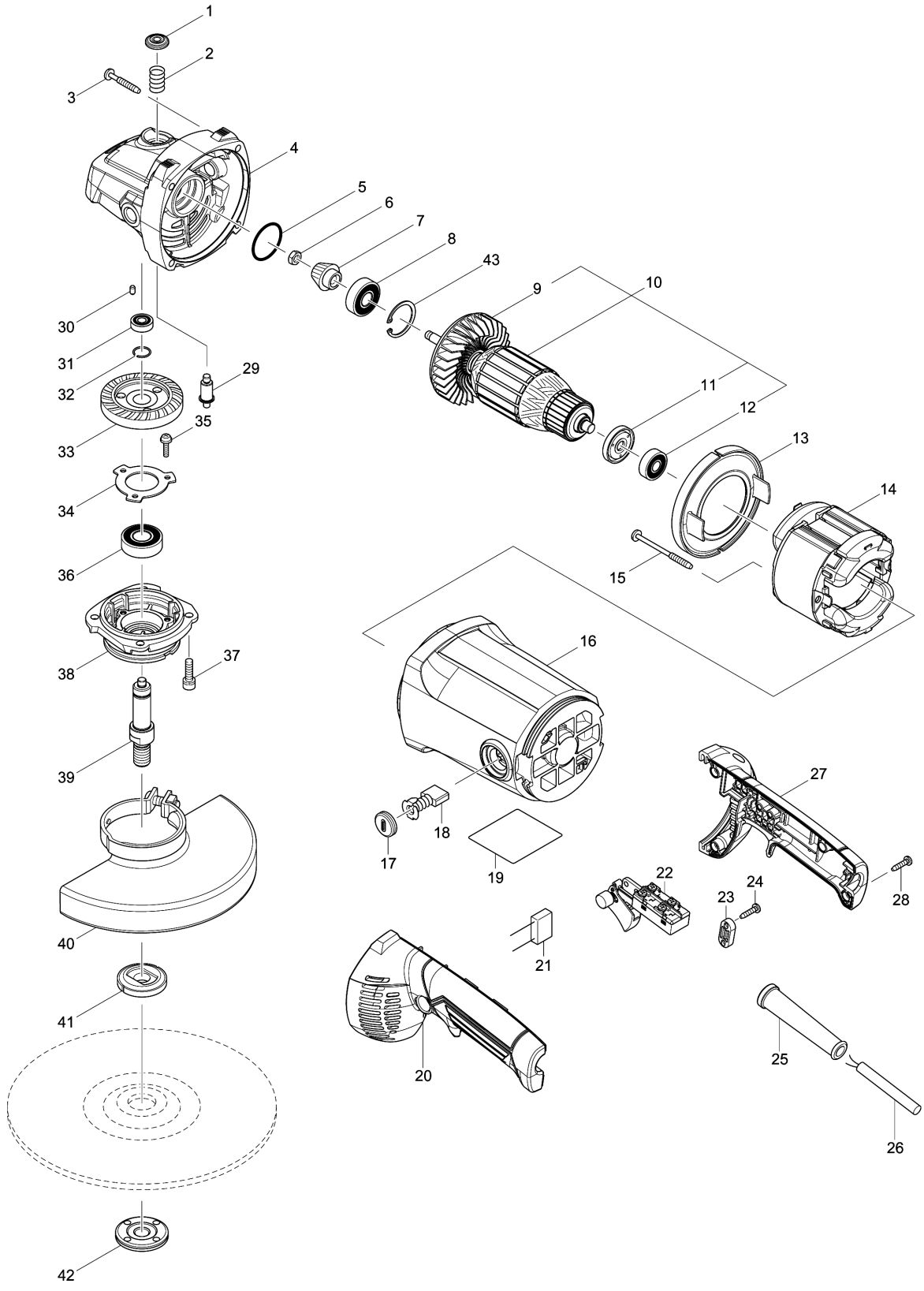

Model No.M0920 180MM ANGLE GRINDER

分解圖號	零件編號	品名	交換	數量	New/Old	選擇1	選擇2	註記
001	454462-8	PIN CAP		1				
002	234298-9	COMPRESSION SPRING 12		1				
003	266840-8	TAPPING SCREW 5X35		4				
004	319004-4	GEAR HOUSING		1				
005	213459-4	O RING 32		1				
006	264010-3	HEX.NUT M7		1				
007	227616-8	SPIRAL BEVEL GEAR 16		1				
008	211129-9	BALL BEARING 6201DDW		1				
009	240081-4	FAN 80		1				
010	517893-3	ARMATURE ASS'Y 220V		1				
D10		INC. 9,11,12						
011	681666-1	INSULATION WASHER		1				
012	211381-9	BALL BEARING 629ZZ		1				
013	454555-1	BAFFLE PLATE		1				
014	636383-8	FIELD 220V		1				
015	266842-4	TAPPING SCREW 5X65		2				
016	143251-3	MOTOR HOUSING COMPLETE		1				
C10	644502-2	BRUSH HOLDER 7-18		2				
017	644802-0	HOLDER CAP		2				
018	191957-7	A.C. CARBON BRUSH CB-204		1				
019	850Y98-5	M0920 NAME PLATE		1				
020	187638-9	HANDLE SET		1				
D10		INC. 27						
021	645240-9	NOISE SUPPRESSOR		1				
022	650115-9	SWITCH TN31-2		1				
023	687124-5	STRAIN RELIEF		1				
024	266841-6	TAPPING SCREW 4X18		2				
025	682574-9	CORD GUARD 10-90		1				
026	694407-6	POWER SUPPLY CORD 1.0-2-2.0		1				
027	187638-9	HANDLE SET		1				
D10		INC. 20						
028	266841-6	TAPPING SCREW 4X18		4				
029	256550-5	SHOULDER PIN 5		1				
030	263002-9	RUBBER PIN 4		1				
031	211382-7	BALL BEARING 607ZZ		1				
032	234299-7	RING SPRING 13		1				
033	227615-0	SPIRAL BEVEL GEAR 53A		1				
034	285851-4	BEARING RETAINER		1				

Model No.M0920 180MM ANGLE GRINDER

分解圖號	零件編號	品名	交換	數量	New/Old	選擇1	選擇2	註記
035	911123-8	PAN HEAD SCREW M4X14		3				
036	211487-3	BALL BEARING 6202DDW		1				
037	265541-5	HEX. SOCKET HEAD BOLT M6X22		4				
038	319169-2	BEARING BOX		1				
039	326300-3	SPINDLE		1				
040	122890-2	WHEEL COVER 180K ASS'Y		1				
C10	213017-6	O RING 6		1				
C20	265198-2	+PAN HEAD SCREW M8X25		1				
041	224415-9	INNER FLANGE 42		1	*			
041-1	224490-5	INNER FLANGE 14-45	O	1				
042	224584-6	LOCK NUT 14-45		1				
043	257965-9	RETAINING RING (INT) R-32		1				
A01	142088-5	GRIP 36 COMPLETE		1				
A02	782407-9	LOCK NUT WRENCH 35		1	*			
A02-1	782034-2	LOCK NUT WRENCH 35	O	1				

Please order the parts with part number.

Print Date 2022/2/11