

Model No.M0801 16MM HAMMER DRILL

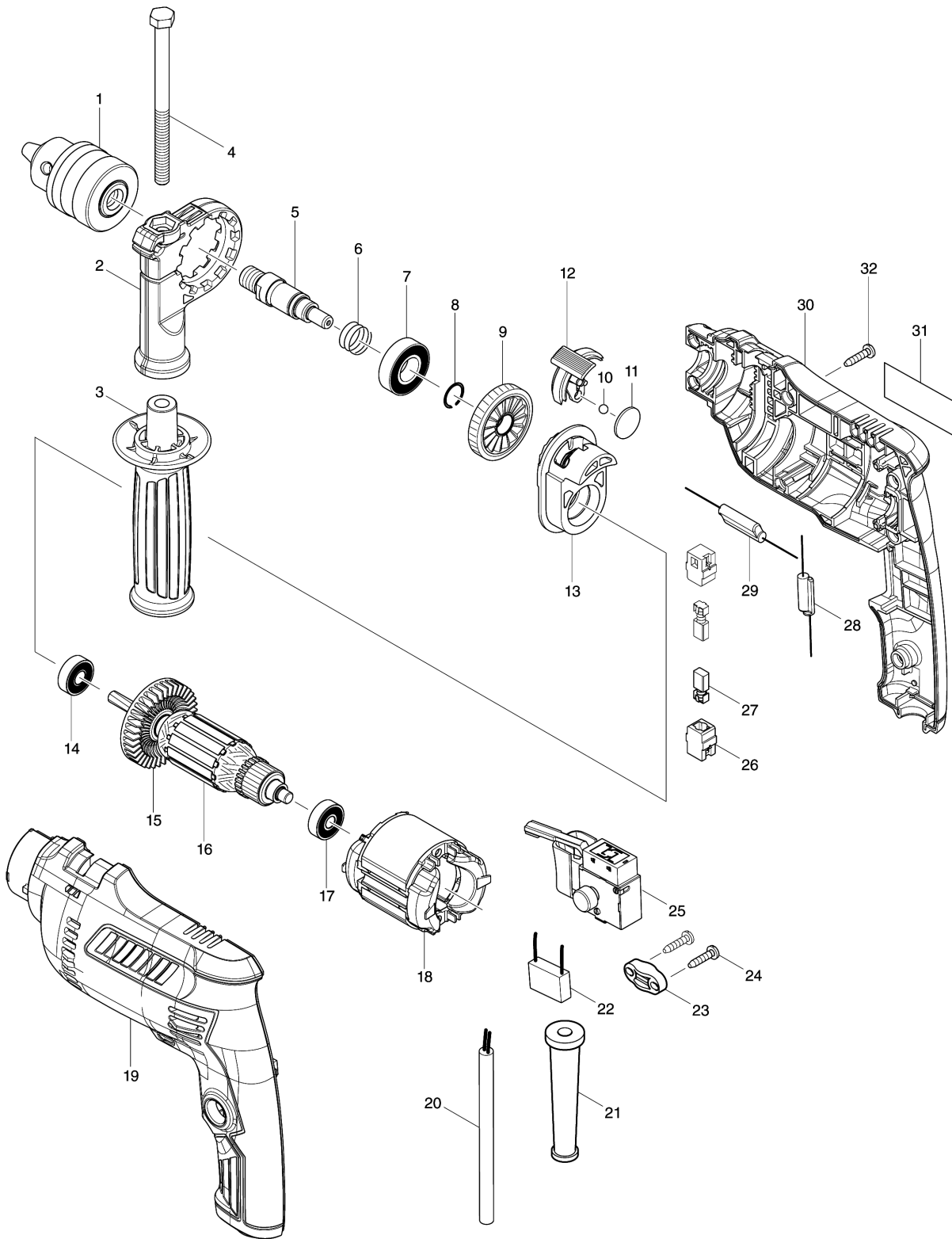

Model No.M0801 16MM HAMMER DRILL

分解圖號	零件編號	品名	交換	數量	New/Old	選擇1	選擇2	註記
001	766023-5	夾頭 S13		1				
002	454126-4	把手座		1				
003	142083-5	把手頭 36		1				
004	265495-6	螺絲 M8X110		1				
005	326278-0	主轴		1				
006	234342-2	COMPRESSION SPRING 16		1				
007	211484-9	軸承 6002LLB		1				
008	233925-5	彈簧圈13		1				
009	227764-3	斜齿轮 39		1				
010	216038-7	钢珠 5.0		1				
011	346676-2	盘 19		1				
012	454375-3	调节杆		1				
013	142074-6	凸轮架总成		1				
C10	141994-1	CUM COMPLETE		1				
014	210044-4	培林 608DDW		1				
015	240127-6	FAN 52		1				
016	511A66-6	ARMATURE ASS'Y 115V		1				
D10		INC. 14,15,17						
017	210045-2	滾珠軸承 627DDW		1				
018-1	634821-4	FIELD		1				
019-1	183N01-8	HOUSING SET		1				
C10	263002-9	橡皮銷 4		2				
D10		INC. 30						
020	693454-4	POWER SUPPLY CORD 0.75-2-2.0		1				
021-1	682504-0	CORD GUARD 10-85		1				
022	645190-8	噪音防止器		1				
023	687140-7	STRAIN RELIEF		1				
024	266841-6	自攻螺絲4X18		2				
025	650713-9	SWITCH FA2-6/1BEK		1				
026	643566-3	碳刷座 5X8		2				
027	191956-9	CARBON BRUSH CB-75		1				
028	646147-2	防磁波線圈		1				
029	646153-7	电感		1				
030-1	183N01-8	HOUSING SET		1				
C10	263002-9	橡皮銷 4		2				
D10		INC. 19						
031-1	851A94-2	M0801 NAME PLATE		1				
032	266841-6	自攻螺絲4X18		7				
A01	763453-1	夾頭板手 S13		1				
A02	418163-2	夾頭板手套 10		1				

Model No.M0801 16MM HAMMER DRILL

分解圖號	零件編號	品名	交換	數量	New/Old	選擇1	選擇2	註記
A03	821727-7	PLASTIC CASE		1				
C10	452432-1	SLIDE LATCH		2				
C20	806G57-9	MAKITA MT LOGO LABEL		1				
A04	D-52308	74PCS. BIT SET, MM, TYPE NZ		1				
A05	D-53039	FILM FOR CASE A&C		1				

Please order the parts with part number.

Print Date 2022/2/11