

Model No.M6201 13MM(1/2")DRILL

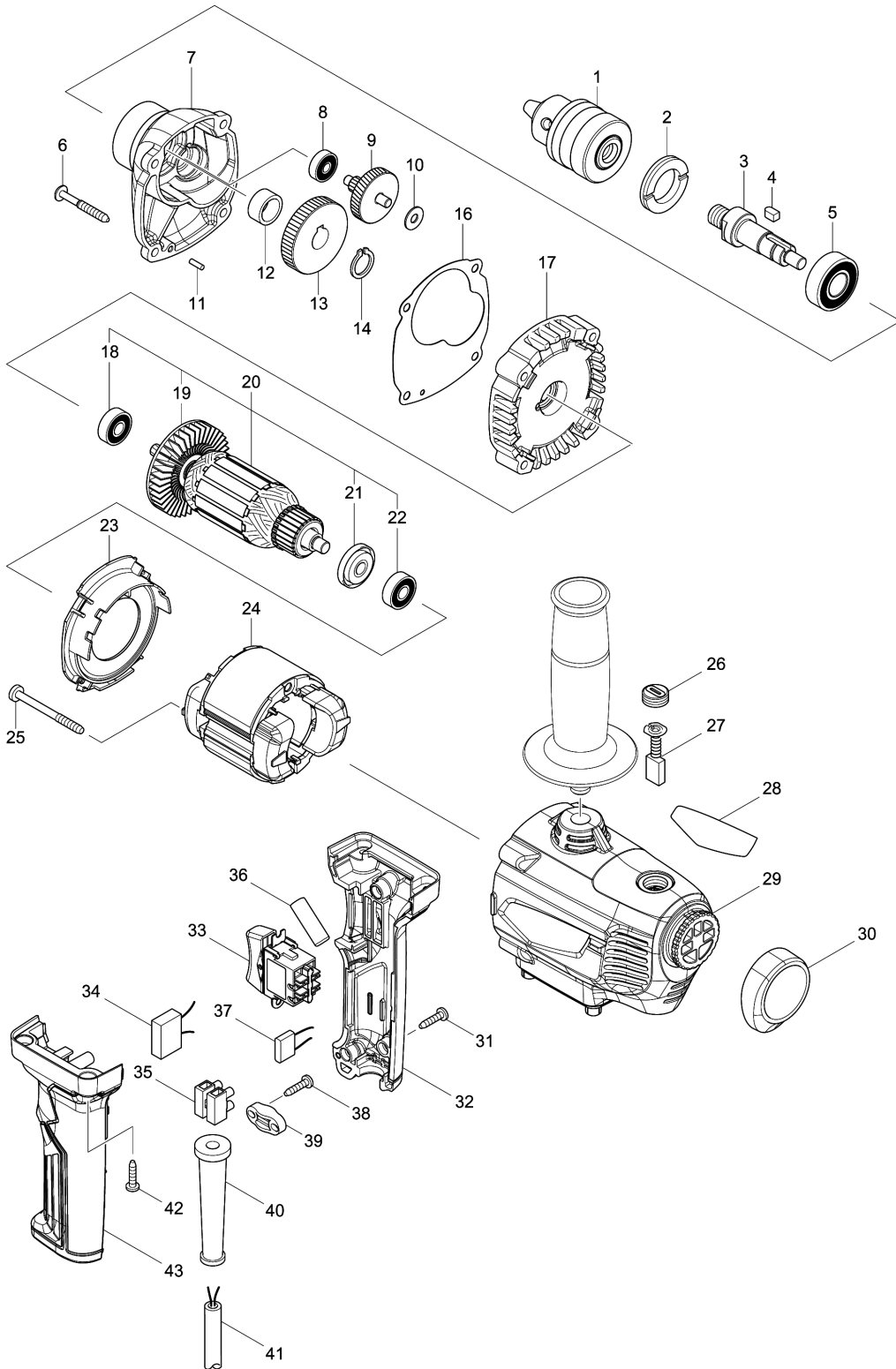

Model No.M6201 13MM(1/2")DRILL

分解圖號	零件編號	品名	交換	數量	New/Old	選擇1	選擇2	註記
001	766023-5	夾頭 S13		1				
002	285848-3	軸承保持器 23-36		1				
003	326600-1	車心		1				
004	254211-1	鍵5		1				
005	211487-3	培林 6202DDW		1				
006	266211-9	螺絲 5X40		4				
007	142841-9	齒輪箱		1				
C10	263002-9	橡皮銷 4		1				
008	211499-6	培林 626ZZ		1				
009	226028-2	齒輪組 7-41 F/6300LR,UT2201		1				
010	253804-1	平墊片 6		1				
011	256180-2	銷 3		1				
012	257018-4	環 15		1	*			
012-1	257018-4	環 15	○	1				
013	221261-1	正齒輪47 F/DP4700,UT2201		1				
014	961054-1	檔圈 S-14		1				
016	442207-6	墊片		1				
017	142840-1	齒輪箱蓋		1				
C10	263002-9	橡皮銷 4		1				
018	210029-0	軸承 608ZZ		1				
019	241850-6	風葉60 F/HR2400,6905H		1				
020	518501-9	馬達心 115v		1				
D10		INC. 18,19,21,22						
021	681644-1	絕緣墊片		1				
022	210029-0	軸承 608ZZ		1				
023	455343-9	擋板		1				
024	594656-4	外線圈 115v		1				
C10	654020-2	碳刷座圈 CB-5		2				
C21	654485-8	PARALLEL SPLICE		2				
025	266418-7	螺絲5X55 F/HR4002		2				
026-1	643750-0	碳刷座蓋		2				
027	191963-2	碳刷CB-303 C/A-81664		1				
028	850W10-3	M6201 NAME PLATE		1				
029	143260-2	MOTOR HOUSING COMPLTE		1				
C10	644501-4	碳刷座 5X11		2				
030	424654-3	蓋子		1				
031	266326-2	螺絲 M4X18		3				
032	183B05-8	SWITCH HANDLE SET		1				
D10		INC. 43						

Model No.M6201 13MM(1/2")DRILL

分解圖號	零件編號	品名	交換	數量	New/Old	選擇1	選擇2	註記
033	650732-5	開關		1				
034	645190-8	噪音防止器		1				
035	654531-7	線端裝置 F/TW1000		1				
036	688172-7	濾波器		1				
037	646755-9	電阻 F/TW0350,1K		1				
038	266326-2	螺絲 M4X18		2				
039	687149-9	電線固定片		1				
040	682566-8	電線保護管10		1				
041	693504-5	電線 1.25-2-2.0		1				
042	266326-2	螺絲 M4X18		4				
043	183B05-8	SWITCH HANDLE SET		1				
D10		INC. 32						
A01-1	140N59-0	GRIP 36 COMPLETE		1				
A02	418163-2	夾頭板手套 10		1				
A03	763453-1	夾頭板手 S13		1				

Please order the parts with part number.

Print Date 2022/2/11