

Model No.HR2653 26MM COMBI.HAMMER W/SELF DUST

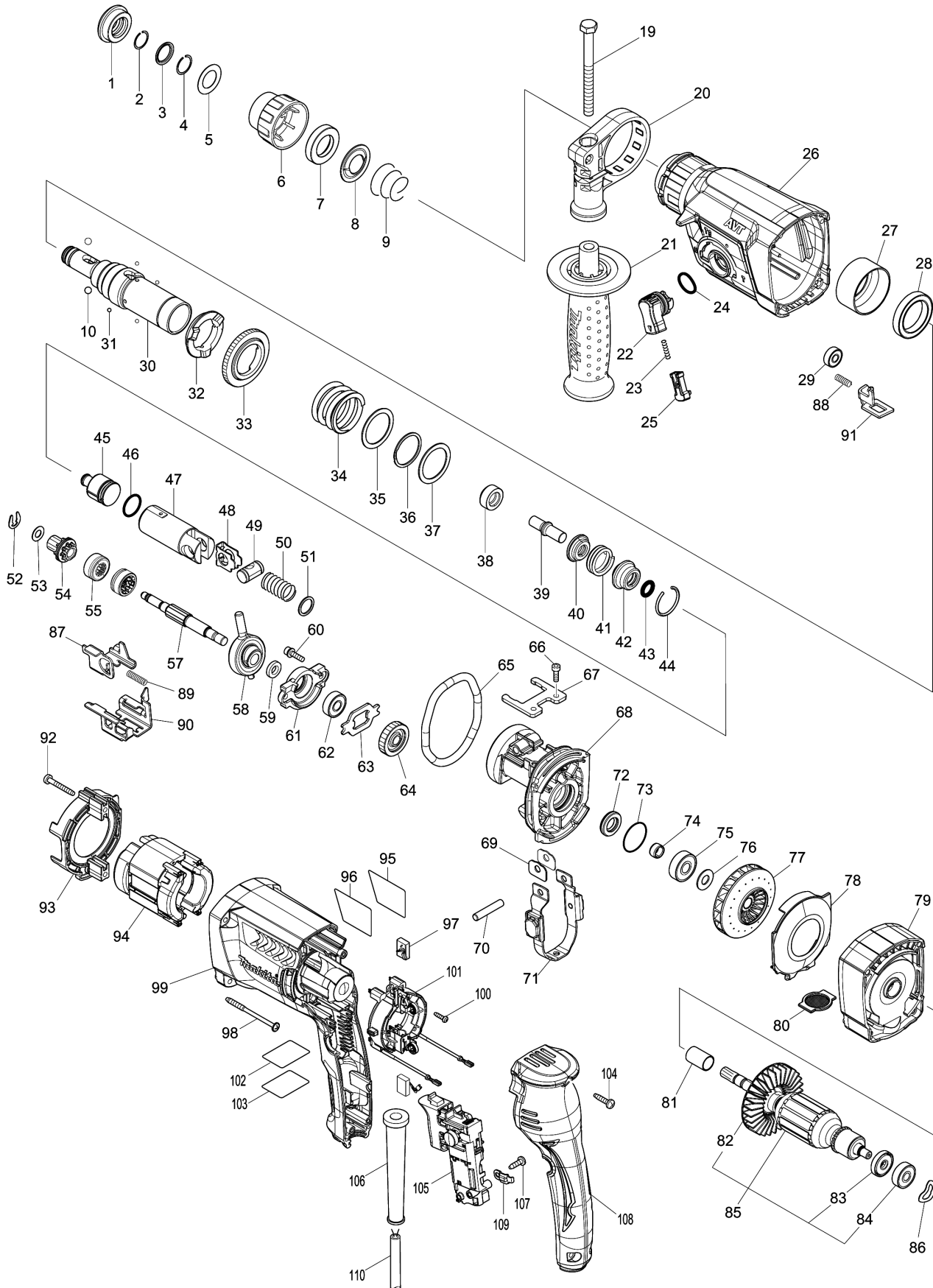

Model No.HR2653 26MM COMBI.HAMMER W/SELF DUST

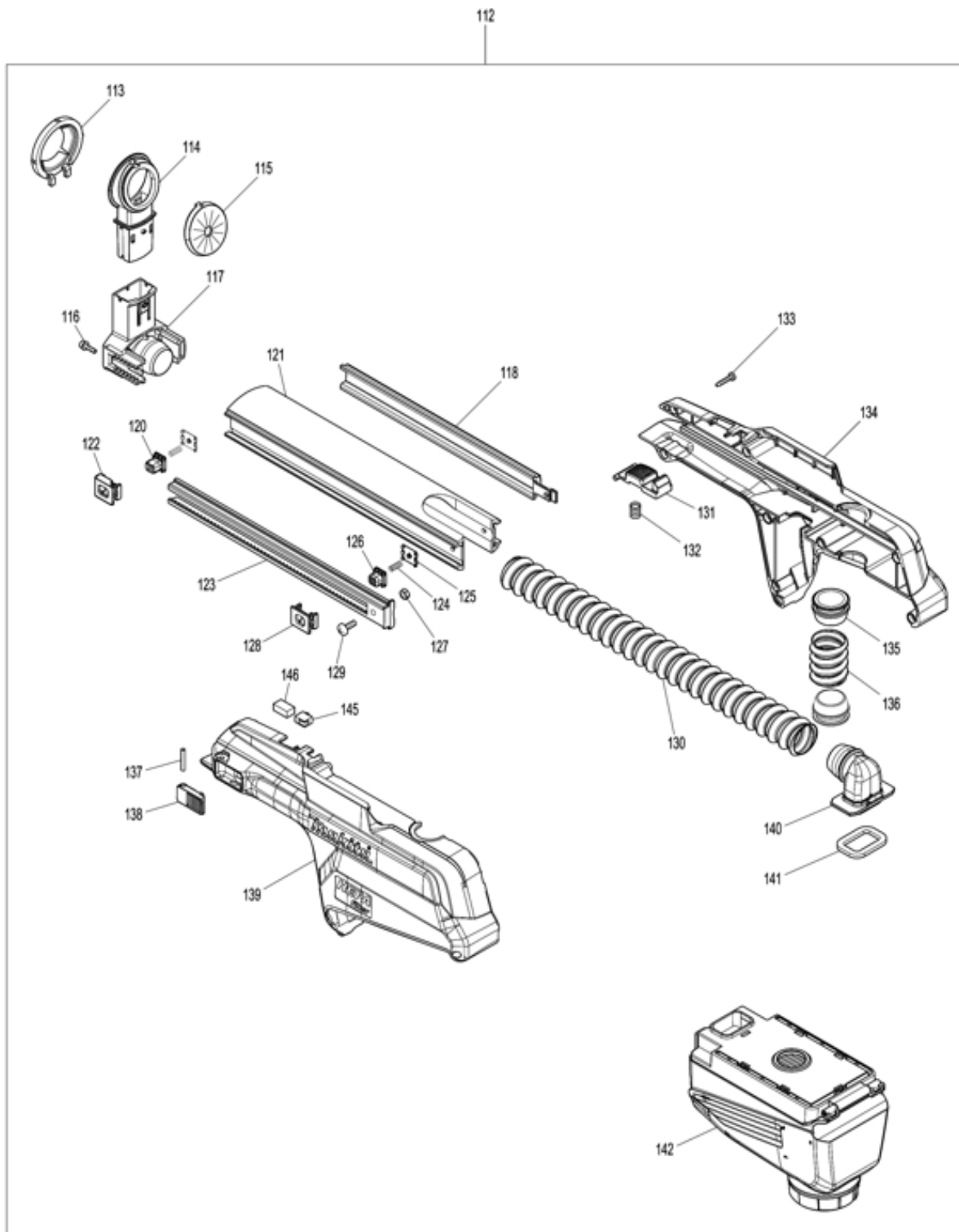

Model No.HR2653 26MM COMBI.HAMMER W/SELF DUST

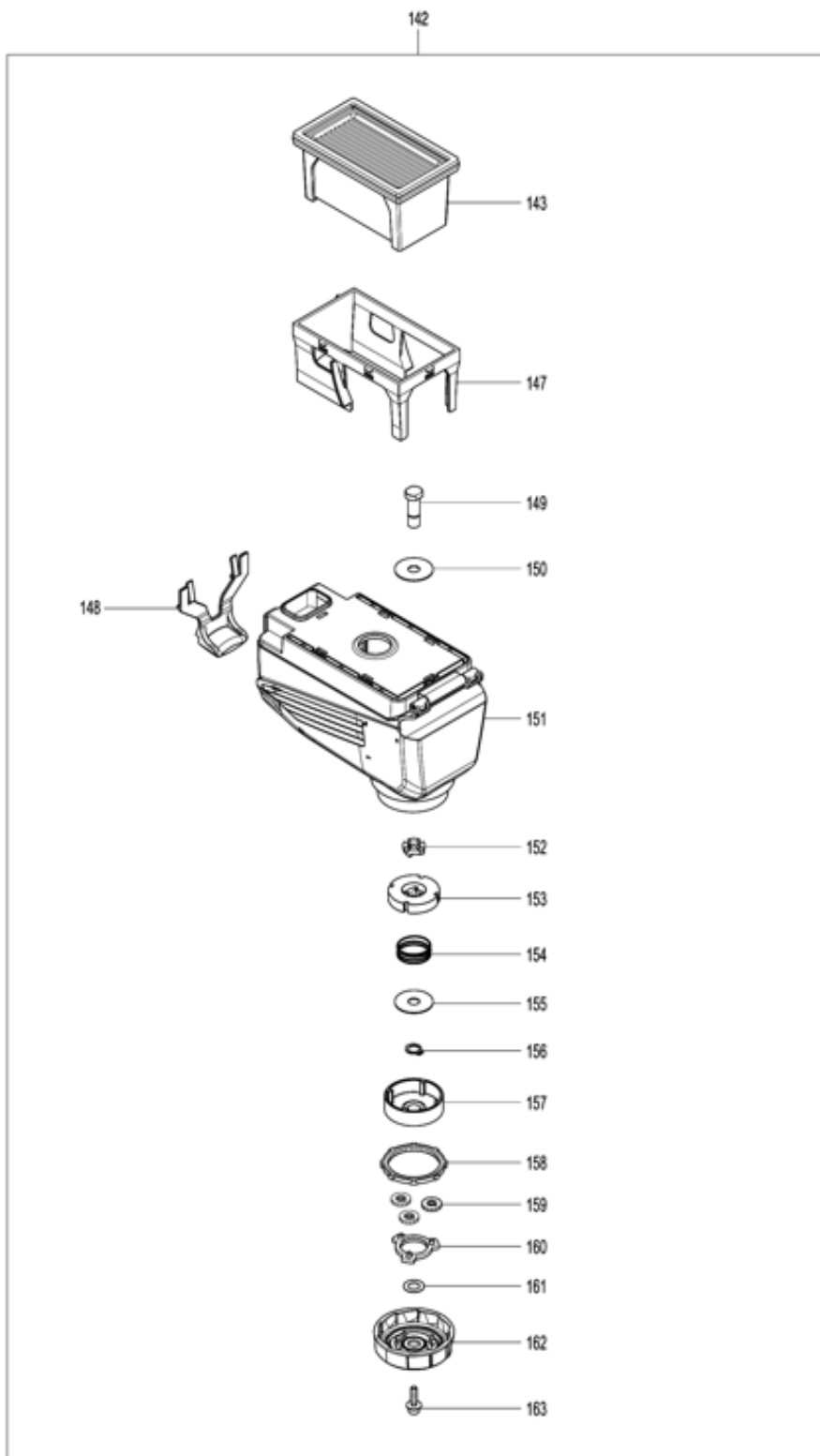

Model No.HR2653 26MM COMBI.HAMMER W/SELF DUST

分解圖號	零件編號	品名	交換	數量	New/Old	選擇1	選擇2	註記
001	286288-8	帽 35		1				
002	233989-9	彈簧圈 14		1				
003	346834-0	墊圈 16		1				
004	233992-0	彈簧圈		1				
005	267114-0	平墊圈17		1				
006	455393-4	切替圈蓋		1				
007	325813-1	環 21		1				
008	346177-0	引導華司		1				
009	233916-6	彈簧 21-29		1				
010	216022-2	鋼珠 7		2				
019	266745-2	螺絲 M8X90		1				
020	453129-5	把手座		1				
021	158057-6	把手頭 36		1				
C10	931402-8	六角螺帽 M8		1				
022	161656-5	變速桿		1				
023	234264-6	壓縮彈簧 3		1				
024	213278-8	O圈17		1				
025	457709-9	鎖定按鈕		1				
026	140D00-3	齒輪箱		1				
C10	213636-8	油封25		1				
027	331890-3	隔套		1				
028	211294-4	培林6806LLU		1				
029	210028-2	軸承 606ZZ		1				
030	142972-4	槍管		1				
C10	213344-1	油封9		1				
031	216019-1	鋼珠 3		4				
032	332139-4	驅動法蘭		1				
033	227360-7	直齒輪51		1				
034	234148-8	彈簧 31		1				
035	267153-0	平華司 30		1				
036	257932-4	扣溝華司		1				
037	267153-0	平華司 30		1				
038	325783-4	隔套 9B		1				
039	325789-2	迫擊座 A		1				
040	325792-3	華司 10		1				
041	234149-6	彈簧 20		1				
042	325793-1	O圈座 B		1				
043	213073-6	圈 9		1				
044	233979-2	彈簧圈 28		1				
045	325784-2	鏈		1				
046	213258-4	O圈 17.5		1				

047	310345-1	活塞汽缸		1				
048	346036-8	導向板		1				
049	324215-8	活塞桿		1				
050	234098-7	扭力彈簧 14		1				
051	267447-3	平華司 14		1				
052	257336-0	停止圈 EXT U-6		1				
053	253186-1	F 華士 7		1				
054	227359-2	直齒輪10		1				
055	332125-5	離合器凸輪		2				
057	326448-1	凸輪軸		1				
058	219023-9	波浪軸承 10		1				
059	257321-3	圈 8		1				
060	266437-3	內六角頭螺絲 M4X16		2				
061	310344-3	培林盒		1				
062	211032-4	培林 608ZZ		1				
063	285735-6	培林押板		1				
064	227719-8	齒輪26		1				
065	213728-3	O圈 68		1				
066	265353-6	螺絲M4X12 F/4340CT,50CT		2				
067	346222-1	板		1				
068	141573-5	內殼組		1				
069	346180-1	重量座引導片		2				
070	256246-8	銷6		1				
071	161655-7	平衡器		1				
072	213678-2	油封 12		1				
073	213407-3	環26		1				
074	262569-4	套筒9		1				
075	210042-8	軸承 F/MT411		1				
076	253733-8	F華士 9		1				
077	240182-8	FAN 65		1				
078	457711-2	擋板		1				
079	457710-4	風扇罩		1				
080	457713-8	濾板		1				
081	262184-4	SLEEVE 10		1				
082	240121-8	風葉65		1				
083	681652-2	絕緣華司		1				
084	210023-2	培林 627DDW		1				
085	515421-8	馬達心110V		1				
D10		INC. 82-84						
086	267804-5	波浪墊片15 F/HR2230		1				
087	347230-5	更換板 B		1				
088	233360-7	彈簧 4		1				
089	234343-0	壓縮彈簧5		1				
090	347229-0	更換板 A		1				

091	347228-2	鎖板		1			
092	266361-0	螺絲 4X30		2			
093	451527-7	擋板		1			
094	621871-8	外線圈		1			
095	819390-8	清楚貼紙		1			
096	855F87-1	HR2653 NAME PLATE		1			
097	194074-2	碳刷CB-325 F/9553B		1			
098	266334-3	螺絲4X60 F/HR2460,2MT190		4			
099	451536-6	馬達殼		1			
100	266556-5	攻牙螺絲3X12		2			
101	632K39-7	碳刷座元件		1			
102	855F89-7	HR2653 SERIAL NO. LABEL		1			
103	819389-3	清楚貼紙		1			
104	266326-2	螺絲 M4X18		3			
105	651090-2	開關		1			
106	682566-8	電線保護管10		1			
107	266385-6	螺絲4X14		1			
108	451528-5	手握把蓋		1			
109	687682-1	固定片		1			
110	693514-2	電線1.25-2-2.5		1			
112	127185-8	集塵系統 F/HR2650系列		1			
D10		INC. 113-118,120-142,145,146					
113	424722-2	外部膠套		1			
114	455736-0	集塵前端器		1			
115	424474-5	阻塵帽		1			
116	251568-1	螺栓 M3X12		2			
117	457730-8	集塵座 A		1			
118	457723-5	管蓋		1			
120	457718-8	按鈕 B		1			
121	326988-9	SLIDE PIPE		1			
122	457728-5	STOPPER BASE B		1			
123	457722-7	機架導桿		1			
124	232386-6	壓縮彈簧 4		2			
125	457721-9	彈簧板		2			
126	457717-0	按鈕 A		1			
127	931102-0	六角螺母 M4		1			
128	457719-6	底部塞 A		1			
129	251314-2	螺絲 M4X12		1			
130	245045-3	軟管30 D		1			
131	458668-0	鎖定桿		1			
132	231316-4	彈簧 7		1			
133	266130-9	螺絲 PT3X6		8			
134	183K50-7	外殼組		1			

D10		INC. 139					
135	457712-0	接合套		2			
136	245047-9	軟管30 C		1	*		
136-1	245042-9	軟管30 C	O	1			
137	256158-5	插銷 3		1			
138	457720-1	PUSH LEVER		1			
139	183K50-7	外殼組		1			
D10		INC. 134					
140	457724-3	INNER PIPE		1			
141	457725-1	SPONGE SHEET B		1			
142	199586-0	集塵系統 F/HR2650系列		1			
D10		INC. 143,147-163					
143	199557-7	過濾元件(HEPA) DX06/07/08/09/HR265*系列		1			
145	458687-6	塞子		1			
146	422315-9	阻尼器		1			
147	457727-7	FILTER GUARD		1			
148	453148-1	RELEASE LEVER		1			
149	327221-2	SHAFT		1			
150	253431-4	FLAT WASHER 8		1			
151	140G88-1	DUST CASE COMPLETE		1			
C10	256533-5	ROD 2.5		1			
C20	423426-3	SPONGE SHEET A		1			
C30	457726-9	過濾器底座		1			
152	310918-0	CAM		1			
153	310919-8	HAMMER		1			
154	232482-0	COMPRESSION SPRING 21		1			
155	253431-4	FLAT WASHER 8		1			
156	961004-6	擋圈 S-8		1			
157	226856-5	SUPER GEAR 17		1			
158	226857-3	INTERNAL GEAR 49		1			
159	226855-7	SUPER GEAR 15		3			
160	140F90-8	CARRIER COMPLETE		1			
161	253430-6	FLAT WASHER 8		1			
162	140H88-7	DIAL COMPLETE		1			
C10	422431-7	SPONGE SHEET		1			
163	922129-1	H.S.H.BOLT M4X16 WITH WG		1			
A01	324219-0	深度定規		1			
A02	424474-5	阻塵帽		5			
A03	821780-3	PLASTIC CASE		1			
C10	162302-3	推板 (充電式使用)		2			
A07	D-57059	四溝鑽頭組—10支裝/SET		1			
B01	196967-9	HAMMER SERVICE KIT		1			
C10	195127-0	OIL VESSEL SET		2			

D10		INC. 1,2,4,10,43,44,46,97							
-----	--	---------------------------	--	--	--	--	--	--	--

Please order the parts with part number.

Print Date 2020/8/17