

Model No.DVC660 DC BACKPACK VACUUM CLEANER

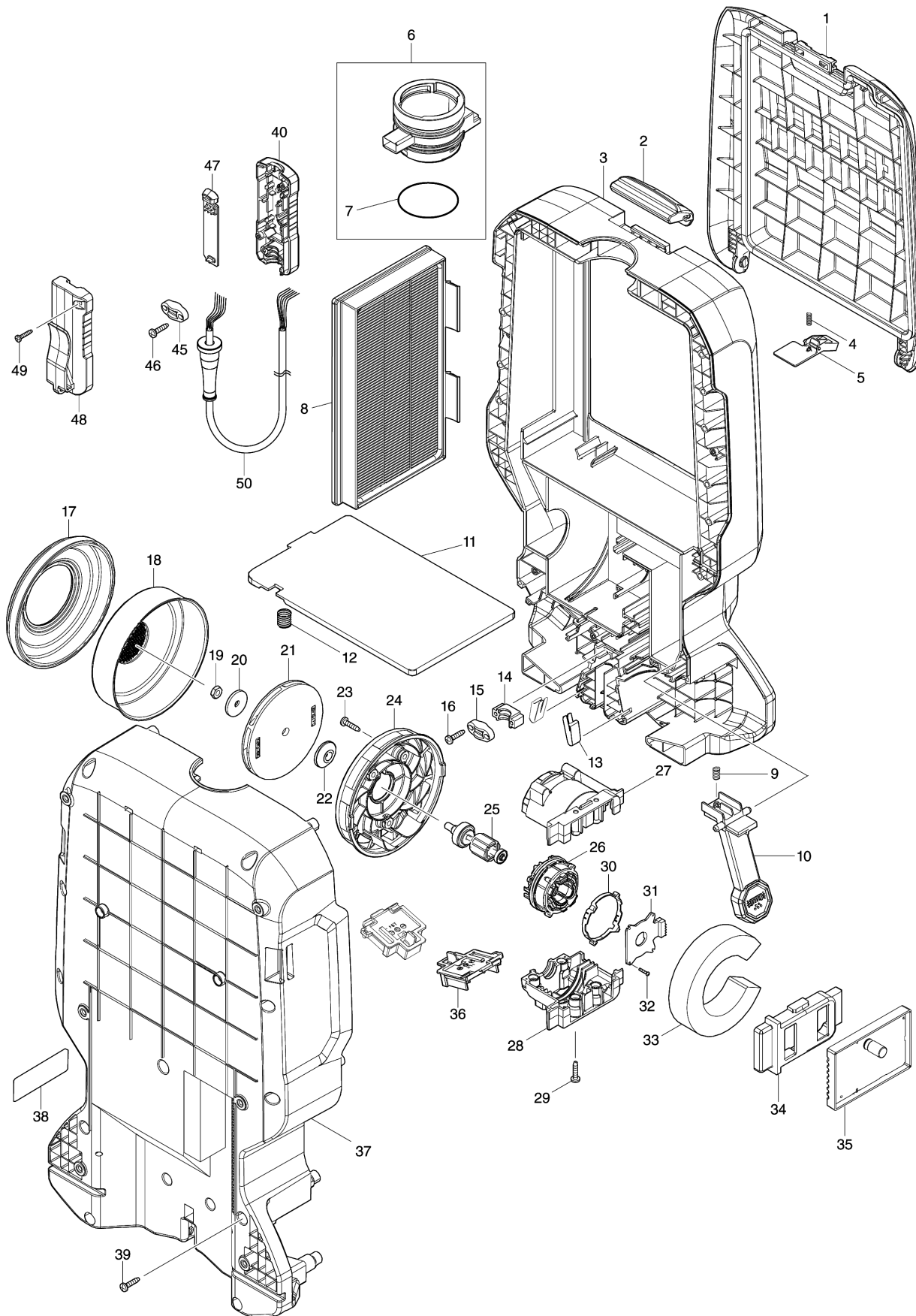

Model No.DVC660 DC BACKPACK VACUUM CLEANER

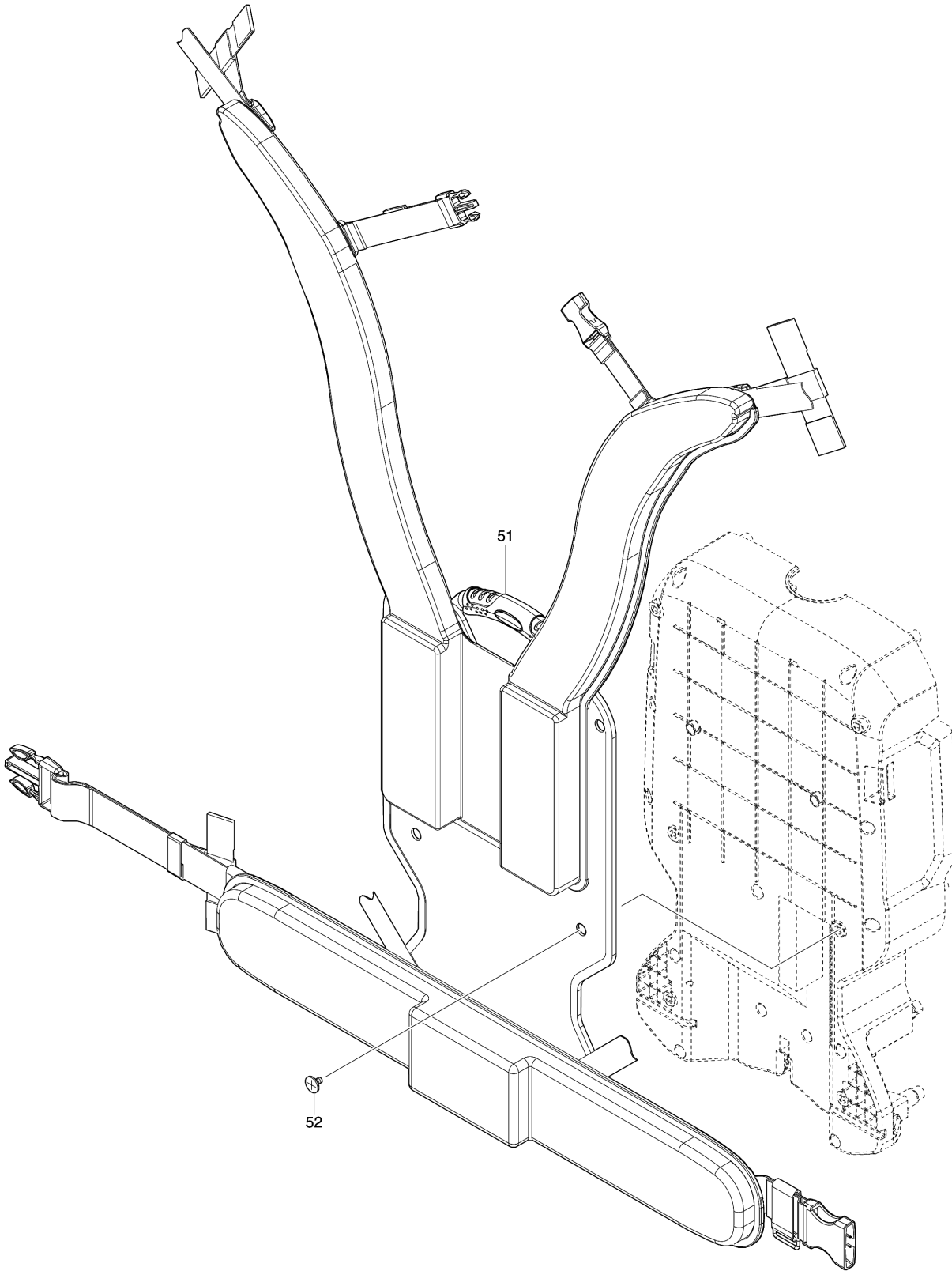

Model No.DVC660 DC BACKPACK VACUUM CLEANER

分解圖號	零件編號	品名	交換	數量	New/Old	選擇1	選擇2	註記
001	140P97-4	DUST BOX COVER COMPLETE		1				
C10	422536-3	SEAL A		1				
002	127480-6	LATCH ASSEMBLY		1				
003	140P91-6	UPPER HOUSING COMPLETE		1				
C10	422534-7	BAND DAMPER D		1				
C20	422550-9	BAND DAMPER A		1				
004	232389-0	COMPRESSION SPRING 5		1				
005	459912-8	STOPPER PLATE		1				
006	135771-1	進氣組件		1				
D10		INC. 7						
007	213655-4	O圈 56		1				
008	191D12-9	MAIN FILTER H SET		1				
009	232588-4	COMPRESSION SPRING 6		1				
010	140P99-0	LEVER 100 COMPLETE		1				
011	459913-6	PLATE		1				
012	234141-2	COMPRESSION SPRING 12		2				
013	232267-4	LEAF SPRING		2				
014	687051-6	保險片		1				
015	687123-7	電線固定片		1				
016	266326-2	螺絲 M4X18		2				
017	422376-9	SUPPORT RING		1				
018	161804-6	FAN COVER		1				
019	252268-6	HEX. NUT M6		1				
020	322407-3	WASHER 6		1				
021	241851-4	FAN 94		1				
022	313062-2	FLANGE		1				
023	266326-2	螺絲 M4X18		3				
024	456736-3	風扇座		1				
025	619517-8	ROTOR		1				
026	629381-9	STATOR		1				
027	183D13-1	馬達殼體		1				
D10		INC. 28						
028	183D13-1	馬達殼體		1				
D10		INC. 27						
029	266326-2	螺絲 M4X18		4				
030	687464-1	支承		1				
031	620526-2	控制器 B		1				
032	266786-8	平頭螺絲 2*10		4				
033	422370-1	BAND DAMPER C		1				

Model No.DVC660 DC BACKPACK VACUUM CLEANER

分解圖號	零件編號	品名	交換	數量	New/Old	選擇1	選擇2	註記
034	424837-5	支撐 A		1				
035	620C52-9	CONTROLLER		1				
036	644809-6	TERMINAL		2				
037	140P93-2	LOWER HOUSING COMPLETE		1				
C10	422535-5	BAND DAMPER E		1				
C20	422551-7	BAND DAMPER B		1				
038	856K43-4	DVC660 NAME PLATE		1				
039	266326-2	螺絲 M4X18		13				
040	183K74-3	SWITCH CASE SET		1				
C10	818F86-4	SWITCH LABEL		1				
D10		INC. 48						
045	687123-7	電線固定片		1				
046	266326-2	螺絲 M4X18		2				
047	620525-4	副控制器		1				
048	183K74-3	SWITCH CASE SET		1				
C10	818F86-4	SWITCH LABEL		1				
D10		INC. 40						
049	266130-9	螺絲 PT3X6		2				
050	699136-6	POWER SUPPLY CORD UNIT		1				
051	162700-1	HARNESS		1				
052	265008-3	螺絲M5		6				
A01	199453-9	HOSE COMPLETE 32-1.0 SET		1				
A02	166116-2	軟管帶		1				
A03	191C26-2	FILTER BAG SET		1				
A04	197901-2	FLEXIBLE RUBBER NOZZLE SET EU		1				
A05	127082-8	NOZZLE ASSEMBLY		1				
A06	140G19-0	TELESCOPIC PIPE COMPLETE		1				
A07	140G26-3	BENT PIPE COMPLETE		1				
A09	198877-6	ROUND BRUSH SET 28 WHI		1	*			
A09-1	198878-4	ROUND BRUSH SET 28 WHI EU	○	1				
A10	191C30-1	DUST BAG SET		1				
A11	199037-3	SEAT NOZZLE SET 28 WHI		1	*			
A11-1	199038-1	SEAT NOZZLE SET 28 WHI EU	○	1				
A15	198918-8	LONG SASH NOZZLE SET 28 WHI		1	*			

Model No.DVC660 DC BACKPACK VACUUM CLEANER

分解圖號	零件編號	品名	交換	數量	New/Old	選擇1	選擇2	註記
A15-1	198919-6	LONG SASH NOZZLE SET 28 WHI EU	○	1				
A16	199439-3	CREVICE NOZZLE 415 SET		1				

Please order the parts with part number.

Print Date 2020/3/5