

Model No.5008B CIRCULAR SAW 210MM

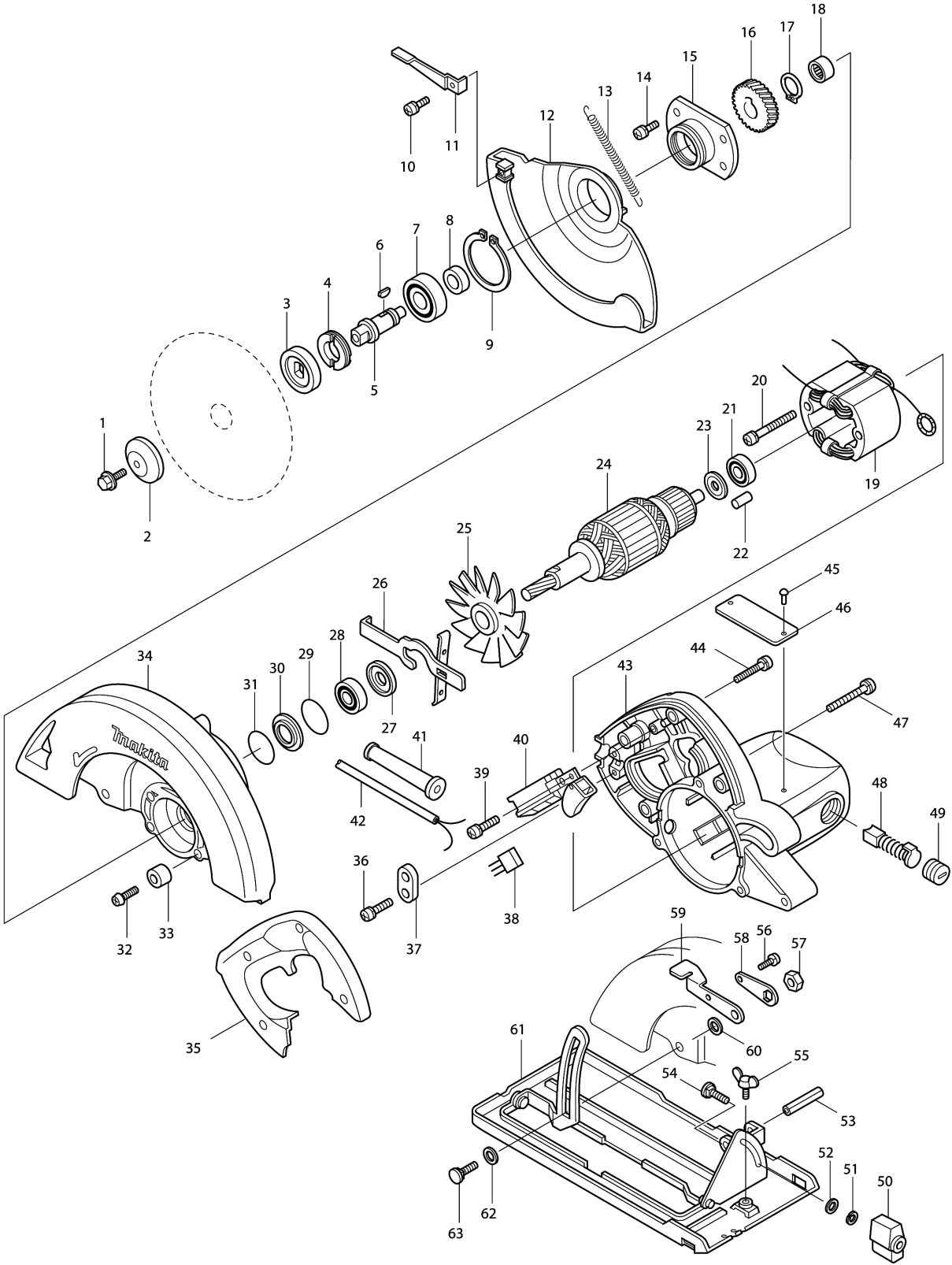

Model No.5008B CIRCULAR SAW 210MM

分解圖號	零件編號	品名	交換	數量	New/Old	選擇1	選擇2	註記
001	251644-1	六角螺絲M8X20 C/265408-7		1				
002-1	224275-9	外法蘭士 40 F/5008B		1				
003-1	224223-8	內法蘭士 40 F/5008B		1	*			
003-2	224360-8	內法蘭士40 F/5008B	S	1				
004	285807-7	培林保持圈29-36		1				
005	321060-2	車心 F/5008B		1	*			
005-1	323789-6	車心 F/5008B	S	1				
006	254032-1	半圓鍵 5		1				
007	211206-7	培林6202LLB		1				
008	257064-7	圈 15 F/5008B		1				
009	961201-4	擋圈S-42 F/5008B,4130		1				
010	911111-5	盤頭螺絲 M4X10		1				
011	341417-1	安全蓋推板 F/5008B		1				
012	315325-2	安全蓋 F/5008B		1				
013-1	231753-2	拉緊彈簧 5 F/5008B		1	*			
013-2	231838-4	TENSION SPRING 4	O	1				
014	911126-2	螺絲M4X16		4				
015	321362-6	培林箱 F/5008B		1				
016	221687-7	螺旋齒輪 43 F/5008B		1				
017	961055-9	檔圈 S-15		1				
018	212052-1	針型培林 1010		1				
019	524535-2	外線圈 F/5008B		1				
C10	654020-2	碳刷座圈 CB-5		2				
C20	654502-4	連接頭 P-2		2				
020-1	911280-2	螺絲 M5X55		2				
021	211033-2	培林608LB		1				
022	263002-9	橡皮銷 4		1				
023-1	681625-5	絕緣墊片		1				
024-1	514855-2	馬達心		1				
025-1	241513-4	風葉92 F/5008B,3501N		1				
026	163113-9	車心擋板 F/5008B		1				
027	213102-5	封油皮12 HM0810 1804N		1				
028	211106-1	軸承 6201LLB		1				
029	213459-4	O 形環 32		1				
030	341736-5	華士 25 F/5008B		1				
031	213412-0	O圈 29 F/5008B		1				
032	251247-1	#NAME?		1	*			
032-1	251224-3	半圓頭螺絲 M6X28	S	1				
033	262502-6	橡皮套筒6		1	*			
033-1	262501-8	橡膠衬套 6	S	1				

Model No.5008B CIRCULAR SAW 210MM

分解圖號	零件編號	品名	交換	數量	New/Old	選擇1	選擇2	註記
034-1	154322-1	刀座 F/5008B		1	*			
D10		INC. 29			*			
034-2	153305-8	刀座 F/5008B	S	1	*			
D10		INC. 18,29			*			
034-3	154888-1	BLADE CASE COMPLETE	S	1				
D10		INC. 18,29						
035	411523-7	把手蓋 F/5008B		1				
036-1	911133-5	螺絲 M4X18		2				
037	687000-3	應變保險		1	*			
037-1	687005-3	應變保險	S	1				
038	645200-1	電容		1				
039	911119-9	螺絲M4X12		1				
040	651121-7	開關8638K2 C/651168-1		1	*			
040-1	651168-1	開關TG923TN-1 C/651172-0	S	1	*			
040-2	651172-0	啟動開關 F/5008B	O	1				
041	682505-8	電線保護管10-90		1	*			
041-1	682506-6	電線保護管12-90	S	1				
042	661214-2	電線1.25-2-2.5 C/693514-2		1	*			
042-1	693564-7	電線2-2-2.5	S	1	*			
042-2	693564-7	電線2-2-2.5	<	1				
043-1	157843-2	馬達座 F/5008B		1				
C10	643660-1	碳刷座6.5-13.5		2				
D10		INC. 22						
044	911148-2	螺絲M4X25		4				
045	953106-2	小釘子0-5		2				
046	854358-7	銘牌 5008B		1				
047	911273-9	螺絲M5X50		3				
048	181047-4	碳刷 CB-154		1				
049	643650-4	碳刷座蓋 6.5-13.5		2	*			
049-1	643650-4	碳刷座蓋 6.5-13.5	O	2				
050	252624-0	蝶螺母 M6 F/5008B		1				
051	942151-2	彈性墊圈 6		1				
052	941151-9	平面墊圈 6		1				
053	951225-8	銷 6X40 F/5008B		1				
054	251919-8	螺絲 M6X20		1				
055	924206-5	蝶螺絲 M5X10		1				
056	911106-8	螺絲M4X8		1				
057	931402-8	六角螺帽 M8		1				
058	341415-5	固定片 F/5008B		1				
059	341416-3	升降推板 F/5008B		1				

Model No.5008B CIRCULAR SAW 210MM

分解圖號	零件編號	品名	交換	數量	New/Old	選擇1	選擇2	註記
060	941201-0	平面墊片8		1				
061-1	134283-1	底座 F/5008B		1				
D10		INC. 50-52,54,55						
062-1	267096-6	F 華士 8 F/5008B		1				
063-1	265965-5	螺絲帽 M8X24		1				
400	721320-6	鋸片210MM F/5008B		1				
401	164095-8	導規		1				
402-2	781203-2	板手13		1				

Please order the parts with part number.

Print Date 2020/1/6