



充電式油壓沖孔機 DPP200



通過油壓沖孔機高速沖壓圓形/橢圓形孔



打孔循環完成後，液壓會自動從工件上拔出打孔器，並將其返回到初始位置，以實現高效的連續打孔。

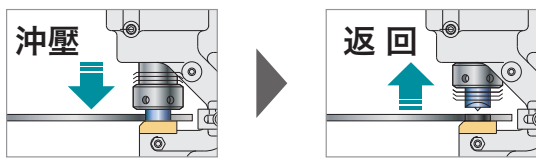

把手可任意方向旋轉 360°

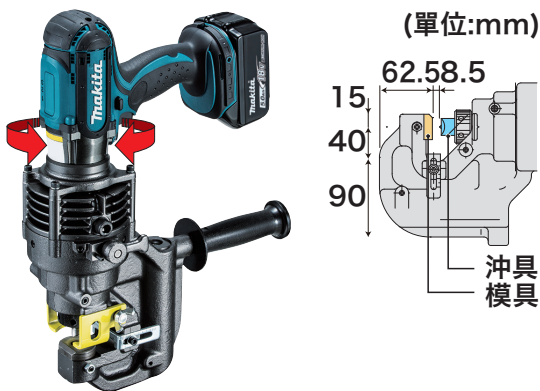

	沖孔能力
扁材	最大 80mm x t8 (中心沖孔)
角材	最小 40mm x 40mm x t3 最大 80mm x 80mm x t8
C型材	最小 75mm x 40mm 最大 100mm x 50mm (法蘭沖孔)

充電式油壓沖孔機 DPP200ZK

最大喉深	40mm
孔洞形狀	圓形 / 橢圓形
最大孔洞尺寸及厚度	抗拉強度 65,000psi 的軟鋼 / 直徑 20mm / 厚度 8mm 抗拉強度 89,000psi 的不鏽鋼 / 直徑 20mm / 厚度 6mm
尺寸 (長 x 寬 x 高)	417x127x315 mm
重量	10.7-10.8 kg

配件：12mm 圓形沖具、12mm 模具、油、板手

※ Z 為單機不附電池與充電器

多功能沖頭適用於多種材料
低碳鋼/不鏽鋼/槽鋼/鋁/銅

扁材

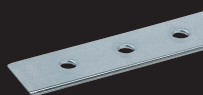

角材





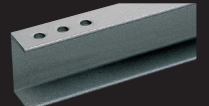

C型材



選購配件

在薄的金屬結構板上打孔可能會導致板變形，並在孔上產生毛刺；如果需要精密沖壓，請參考下表以選擇沖具和模具的最佳組合。

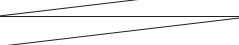
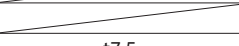
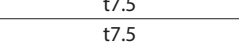
● 圓形沖具						
沖具 		模具 		切割材質		
孔徑 (mm)	料號	孔徑 (mm)	料號	抗拉強度 低碳鋼 (65,000 psi)	C型材 	抗拉強度 不鏽鋼 (89,000 psi)
				厚度		
6	SC05340040	SB6	SC00000203	t2-t4		t3-t4
6.5	SC05340050	SB6.5	SC00000205	t2-t6		t3-t4
8	SC05340060	SB8	SC00000207	t2-t6		t3-t4
8.5	SC05340070	SB8.5	SC00000209	t2-t6		t3-t4
10	SC05340080	SB10	SC00000211	t2-t6	t7.5	t3-t4
11	SC05340090	SB11	SC00000213	t2-t8	t7.5	t3-t6
12	SC05340100	SB12	SC00000215	t2-t8	t7.5	t3-t6
13	SC05340110	SB13	SC00000217	t2-t8	t7.5	t3-t6
14	SC05340120	SB14	SC00000219	t2-t8	t7.5	t3-t6
15	SC05340130	SB15	SC00000221	t2-t8	t7.5	t3-t6
16	SC05340140	SB16	SC05332710	t2-t8	t7.5	t3-t6
18	SC05340150	SB18	SC00000223	t2-t8	t7.5	t3-t6
20	SC05340160	SB20	SC05352510	t2-t8	t7.5	t3-t6

● 橢圓沖具						
沖具 		模具 		切割材質		
孔徑 (mm)	料號	孔徑 (mm)	料號	抗拉強度 低碳鋼 (65,000 psi)	C型材 	抗拉強度 不鏽鋼 (89,000 psi)
				厚度		
6.5 x 10	SC05340200	6.5 x 10B	SC00000244	t2-t6		t3-t4
6.5 x 13	SC05340210	6.5 x 13B	SC00000246	t2-t6		t3-t4
8.5 x 13	SC05340220	8.5 x 13B	SC00000248	t2-t6		t3-t4
8.5 x 17	SC05340230	8.5 x 17B	SC00000250	t2-t6		t3-t4
9 x 13.5	SC05340240	9 x 13.5B	SC00000252	t2-t6		t3-t4
9 x 18	SC05340250	9 x 18B	SC00000254	t2-t6		t3-t4
10 x 15	SC05340260	10 x 15B	SC00000256	t2-t8	t7.5	t3-t6
10 x 20	SC05340270	10 x 20B	SC00000258	t2-t8	t7.5	t3-t6
11 x 16.5	SC05340280	11 x 16.5B	SC00000260	t2-t8	t7.5	t3-t6
12 x 18	SC05340290	12 x 18B	SC00000262	t2-t8	t7.5	t3-t6
13 x 19.5	SC05340300	13 x 19.5B	SC00000264	t2-t8	t7.5	t3-t6
14 x 21	SC05340310	14 x 21B	SC00000266	t2-t8	t7.5	t3-t6

<p>工作台 SC03801080</p>  	<p>滑動止擋器 SC03300790</p>   <p>螺栓 滑動止擋器</p> <p>搭配 SC03300790 使用時 最大喉深可達 40mm</p>	<p>液壓油(150mL) SC00000142</p> 
--	--	---



台灣牧田股份有限公司
www.makita.com.tw

