

# Model No.HR1840 18MM ROTARY HAMMER

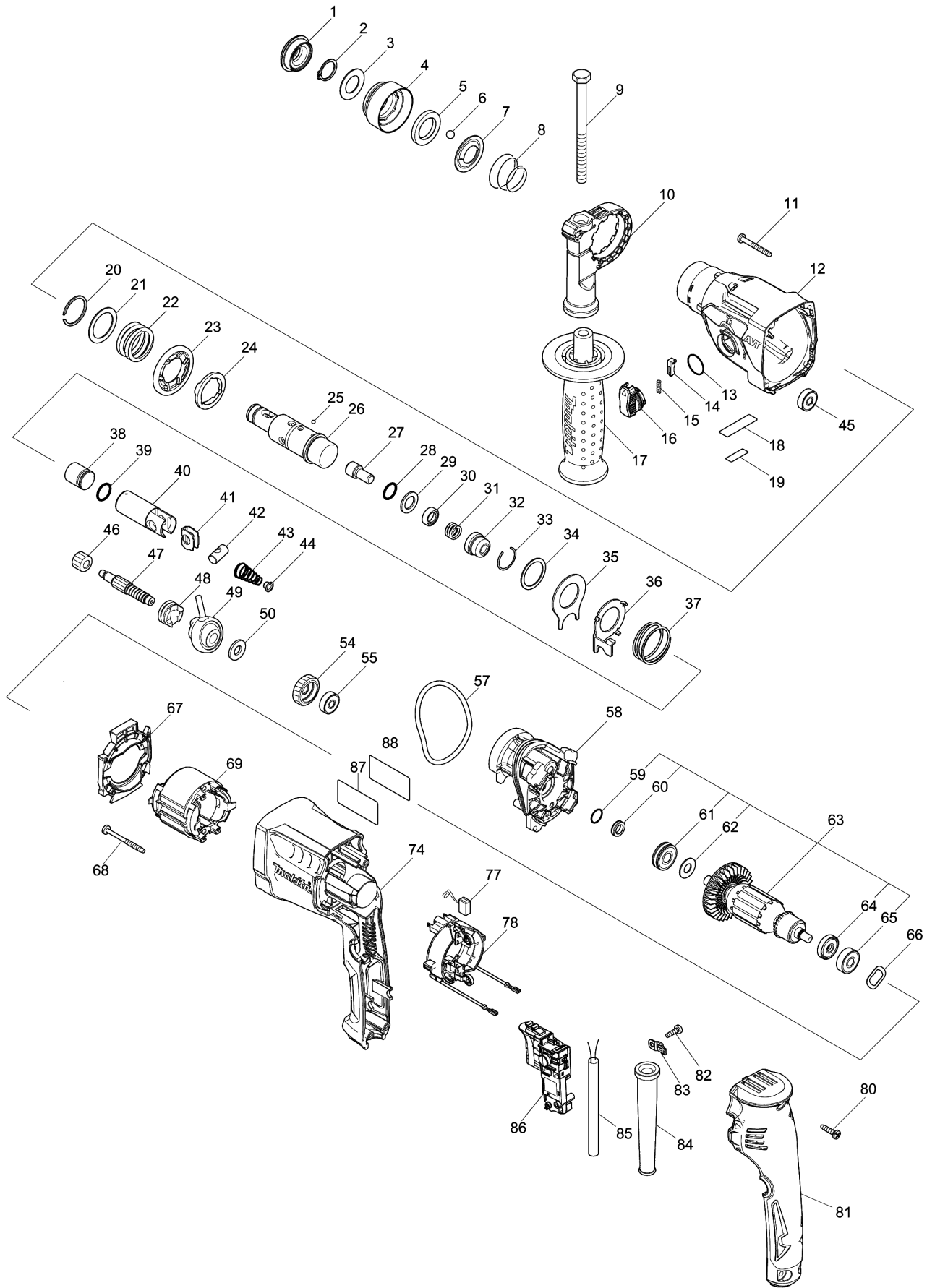

## Model No.HR1840 18MM ROTARY HAMMER

分解圖號	零件編號	品名	交換	數量	New/Old	選擇1	選擇2	註記
001	286037-3	CAP 34		1				
002	961057-5	檔圈 S-17		1				
003	253377-4	FLAT WASHER 17		1				
004	457214-6	CHUCK COVER		1				
005	257416-2	RING 21		1				
006	216022-2	鋼珠 7		2				
007	346177-0	引導華司		1				
008	232347-6	CONICAL COMP. SPRING 21-29		1				
009	921923-8	六角頭螺絲 M8X120		1				
010	417911-6	把手座		1				
011	266053-1	螺絲 4X35		4				
012	144272-8	GEAR HOUSING COMPLETE		1				
C10	213636-8	油封25		1				
C20	211375-4	軸承 6805LLB		1				
013	213278-8	O圈17		1				
014	161568-2	LOCK BUTTON COMPLETE		1				
015	232344-2	COMPRESSION SPRING 3		1				
016	161569-0	CHANGE LEVER COMPLETE		1				
017	158057-6	把手頭 36		1				
C10	931402-8	六角螺帽 M8		1				
018	457356-6	PLATE		1				
019	853K43-5	HR1840 SERIAL NO. LABEL		1				
020	961135-1	擋圈WR-25		1	*			
020-1	347555-7	SPIRAL RETAINING RING 25	O	1				
021	267304-5	墊片25		1				
022	232360-4	COMPRESSION SPRING 25		1				
023	221494-8	SPUR GEAR 44		1				
024	327039-1	DRIVING FLANGE		1				
025	216019-1	鋼珠 3		3				
026	326886-7	TOOL HOLDER		1				
027	326887-5	IMPACT BOLT		1				
028	213117-2	O圈11		1				
029	253380-5	FLAT WASHER 13		1				
030	326888-3	RING 10		1				
031	232357-3	COMPRESSION SPRING 10A		1				
032	327038-3	CUP SLEEVE		1				
033	233942-5	彈簧圈22		1				
034	267175-0	F華士 24		1				
035	345681-6	連接板		1				

036	347128-6	CHANGE PLATE		1			
037	233458-0	扭力彈簧32		1			
038	326889-1	STRIKER		1			
039	213832-8	O-RING 13		1			
040	326890-6	PISTON CYLINDER		1			
041	347127-8	GUIDE PLATE		1			
042	324612-8	活塞連接器		1			
043	232361-2	CONICAL COMP. SPRING 6-13		1			
044	347130-9	SPRING GUIDE		1			
045	211016-2	培林 626LLB		1			
046	221495-6	SPUR GEAR 12		1			
047	326892-2	CAM SHAFT		1			
048	326891-4	CLUCTH CAM		1			
049	219029-7	SWASH BEARING 9		1			
050	253383-9	FLAT WASHER 9		1			
054	221496-4	HELICAL GEAR 23		1			
055	211016-2	培林 626LLB		1			
057	213833-6	O-RING 60		1			
058	144270-2	INNER HOUSING COMPLETE		1			
059	213118-0	O圈 12		1			
060	326893-0	RING 9		1			
061	210162-8	BALL BEARING 609LLU		1			
062	267231-6	華士9		1			
063	513986-4	ARMATURE ASS'Y 115V		1			
D10		INC. 59-62,64,65					
064	681670-0	絕緣華士 F/HR2470		1			
065	210023-2	培林 627DDW		1			
066	267804-5	波浪墊片15 F/HR2230		1			
067	457351-6	BUFFLE PLATE B		1			
068	266069-6	螺絲 PT4X45		2			
069	633991-6	FIELD		1			
074	457353-2	MOTOR HOUSING B		1			
077	194721-5	碳刷 CB-458		1			
078	632K41-0	BRUSH HOLDER UNIT		1			
080	266326-2	螺絲 M4X18		3			
081	457354-0	HANDLE COVER		1			
082	266385-6	螺絲4X14		1			
083	687682-1	固定片		1			
084	682566-8	電線保護管10		1			
085	693514-2	電線1.25-2-2.5		1	*		
085-1	693514-2	電線1.25-2-2.5	<	1			
086	651086-3	SWITCH TG853TB-2		1			
087	853K39-6	HR1840 NAME PLATE		1			

088	813E00-9	CLEAR LABEL		1				
A01	415486-9	定位桿		1				
A02	821706-5	PLASTIC CARRYING CASE		1				
C10	162315-4	栓		2				
C20	324679-6	軸		1				
C30	457340-1	HANDLE		1				
A03	813D89-1	HR1840 PLASTIC CASE LABEL		1				

Please order the parts with part number.

Print Date 2019/8/1