

Model No.DHR281 28MM CRDLS COMBINATION HAMMER

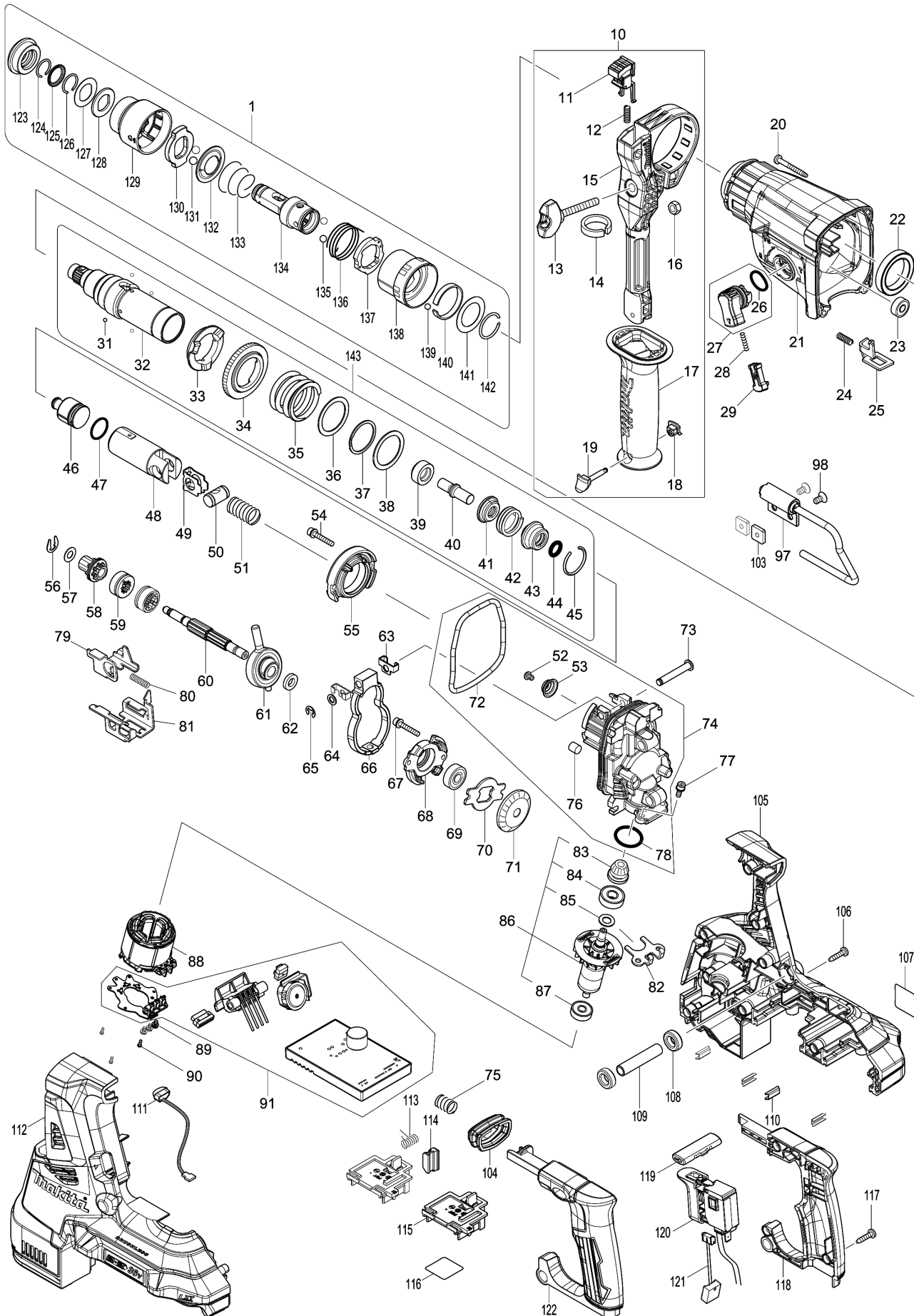

Model No.DHR281 28MM CRDLS COMBINATION HAMMER

分解圖號	零件編號	品名	交換	數量	New/Old	選擇1	選擇2	註記
001	199134-5	TOOL HOLDER SET		1	*			
D10		INC. 123-142			*			
001-1	199138-7	TOOL HOLDER SET	0	1				
D10		INC. 123-142						
010	126882-3	GRIP ASSEMBLY		1				
D10		INC. 11-19						
011	144959-2	LOCK BUTTON COMPLETE		1				
012	233360-7	彈簧 4		1				
013	265625-9	THUMB SCREW M6X50		1				
014	422258-5	SPONGE SHEET		1				
015	458355-1	SIDE HANDLE BASE		1				
016	931302-2	六角螺母 M6		1				
017	458357-7	GRIP 36		1				
018	422255-1	CAP		1				
019	161838-9	FIX PIN		1				
020	266351-3	螺絲 4X35		4				
021	144965-7	GEAR HOUSING COMPLETE		1				
C10	213345-9	油封 25		1				
C20	331890-3	隔套		1				
022	211294-4	培林6806LLU		1				
023	211012-0	軸承 606ZZ		1				
024	233360-7	彈簧 4		1				
025	347228-2	LOCK PLATE		1				
026	213278-8	O圈17		1				
027	135961-6	CHANGE LEVER ASSY		1				
D10		INC. 26						
028	234264-6	壓縮彈簧 3		1				
029	457709-9	LOCK BUTTON		1				
031	216019-1	鋼珠 3		4				
032	144966-5	TOOL HOLDER GUIDE COMPLETE		1				
C10	213344-1	油封9		1				
033	332139-4	驅動法蘭		1				
034	227360-7	直齒輪51		1				
035	234148-8	彈簧 31		1				
036	267153-0	平華司 30		1				
037	257932-4	扣溝華司		1				
038	267153-0	平華司 30		1				
039	325783-4	隔套 9B		1				
040	325791-5	衝擊螺栓B		1				
041	325792-3	華司 10		1				

042	234149-6	彈簧 20		1			
043	325793-1	O圈座 B		1			
044	213073-6	圈 9		1			
045	233979-2	彈簧圈 28		1			
046	325784-2	鏈		1			
047	213258-4	O圈 17.5		1			
048	327079-9	PISTON CYLINDER		1			
049	346036-8	導向板		1			
050	324215-8	活塞桿		1			
051	232449-8	COMPRESSION SPRING 14		1			
052	265627-5	H.S.BUTTON HEAD BOLT M4X6		1			
053	347344-0	SPRING GUIDE		1			
054	922148-7	H.S.H.螺絲 M4X25		2			
055	144960-7	INNER SUPPORT COMPLETE		1			
056	257336-0	停止圈 EXT U-6		1			
057	253186-1	F 華士 7		1			
058	226170-9	SPUR GEAR 10		1			
059	332125-5	離合器凸輪		2			
060	327078-1	CAM SHAFT		1			
061	219030-2	SWASH BEARING 10		1			
062	257321-3	圈 8		1			
063	346538-4	銷座		2			
064	253077-6	F 華士 6		1			
065	961018-5	停止圈 E-5		1			
066	310869-7	COUNTER WEIGHT		1			
067	922148-7	H.S.H.螺絲 M4X25		2			
068	319674-9	BEARING BOX		1			
069	211032-4	培林 608ZZ		1			
070	347343-2	BEARING RETAINER B		1			
071	221599-4	SPIRAL BEVEL GEAR 32		1			
072	213850-6	O-RING 74		1			
073	256536-9	銷 6		1			
074	135962-4	INNER HOUSING ASSY		1			
D10		INC. 52,53,72,76,78					
075	232436-7	COMPRESSION SPRING 10		1			
076	443153-6	塞子		1			
077	922118-6	內六角螺絲 M4X12		2			
078	213008-7	O圈 22.4		1			
079	347230-5	CHANGE PLATE B		1			
080	234343-0	壓縮彈簧5		1			
081	347229-0	CHANGE PLATE A		1			
082	346536-8	保持器		1			
083	144964-9	SPIRAL BEVEL GEAR 11		1			

		COMPLETE					
084	210024-0	培林 608LLU		1			
085	253835-0	平面墊片 8		1			
086	519513-5	ROTOR ASSY		1			
D10		INC. 83-85,87					
087	210022-4	滾珠軸承 626DDW		1			
088	629340-3	STATOR		1			
089	652069-6	平頭螺絲M3X6		3			
090	266490-9	盤頭螺絲 PT 2X6		3			
091	620815-5	CONTROLLER		1			
097	135963-2	HOOK ASSY		1			
098	912207-5	C.H.螺絲M5X10 C/265008-3		2			
103	264002-2	方螺母M5		2			
104	422257-7	BELLOWS		1			
105	183J31-5	HOUSING SET		1			
C10	263005-3	橡皮銷 6		8			
D10		INC. 112					
106	266326-2	螺絲 M4X18		9			
107	854J10-7	DHR281 NAME PLATE		1			
108	422256-9	RUBBER RING 10		2			
109	257438-2	SLEEVE 10		1			
110	346783-1	板		4			
111	620549-0	本體外殼組		1			
112	183J31-5	HOUSING SET		1			
C10	263005-3	橡皮銷 6		8			
D10		INC. 105					
113	233598-4	扭轉彈簧6		1			
114	313226-8	開啟器		1			
115	644809-6	TERMINAL		2			
116	854J13-1	DHR281 SERIAL NO. LABEL		1			
117	266326-2	螺絲 M4X18		4			
118	183J29-2	HANDLE SET		1			
D10		INC. 122					
119	453124-5	切換桿		1			
120	651366-7	SWITCH C3JW-6B-24		1			
121	632L95-3	LEAD UNIT		1			
122	183J29-2	HANDLE SET		1			
D10		INC. 118					
123	286288-8	帽 35		1			
124	233989-9	彈簧圈 14		1			
125	346221-3	華司 16		1			
126	233992-0	彈簧圈		1			
127	267437-6	平華司 17		1			
128	424364-2	橡膠華司 16		1			

129	458358-5	CHUCK COVER		1			
130	327081-2	STOPPER		1			
131	216022-2	鋼珠 7		2			
132	346177-0	引導華司		1			
133	233916-6	彈簧 21-29		1			
134	327080-4	TOOL HOLDER		1			
135	216013-3	鋼珠 6		2			
136	231669-1	扭力彈簧 31		1			
137	345334-7	切替圈		1			
138	418218-3	切替圈蓋		1			
139	216018-3	鋼珠 5.0		1			
140	345335-5	板彈簧		1			
141	267270-6	平墊圈 24		1			
142	233924-7	彈簧圈 21		1			
143	135965-8	TOOL HOLDER ASSY		1			
D10		INC. 31-45					
A01	199135-3	DRILL CHUCK SET		1	*		
A01-1	199139-5	DRILL CHUCK SET	O	1			
A02	194683-7	潤滑油組		1			
A04	331886-4	深度桿		1			
A05	443122-7	布		1			
A07B	***DX04	DUST EXTRACTION SYSTEM		1	*		
D10		COMPO-PARTS			*		
D20		INC. A08			*		
A07-1B	***DX09	DUST COLLECTION SYSTEM SET	<	1			
D10		COMPO-PARTS					
D20		INC. A08					
A08B	424474-5	阻塵帽		5			
A11A	839559-8	INNER TRAY		1			
A11B	839560-3	INNER TRAY		1	*		
A11-1B	835A32-2	INNER TRAY	<	1			
A12	821552-6	工具箱－堆疊型 4		1			
C10	453974-8	塑膠箱門鎖		4			
A13A	817L25-7	DHR281ZJ INDICATION LABEL		1			
A13B	817L29-9	DHR281ZWJ INDICATION LABEL		1			
A14A	817L23-1	DHR281ZJ PLASTIC CASE LABEL		2	*		
A14B	817L28-1	DHR281ZVJ PLASTIC CASE LABEL		2	*		
A14-1A	817L22-3	DHR281ZJ PLASTIC CASE LABEL	O	2			
A14-1B	817L27-3	DHR281ZWJ PLASTIC CASE LABEL	O	2			

E01	818S15-5	CLEAR LABEL		1				
-----	----------	-------------	--	---	--	--	--	--

Please order the parts with part number.

Print Date 2019/10/29