

型號 SG1251 石材開槽切割機

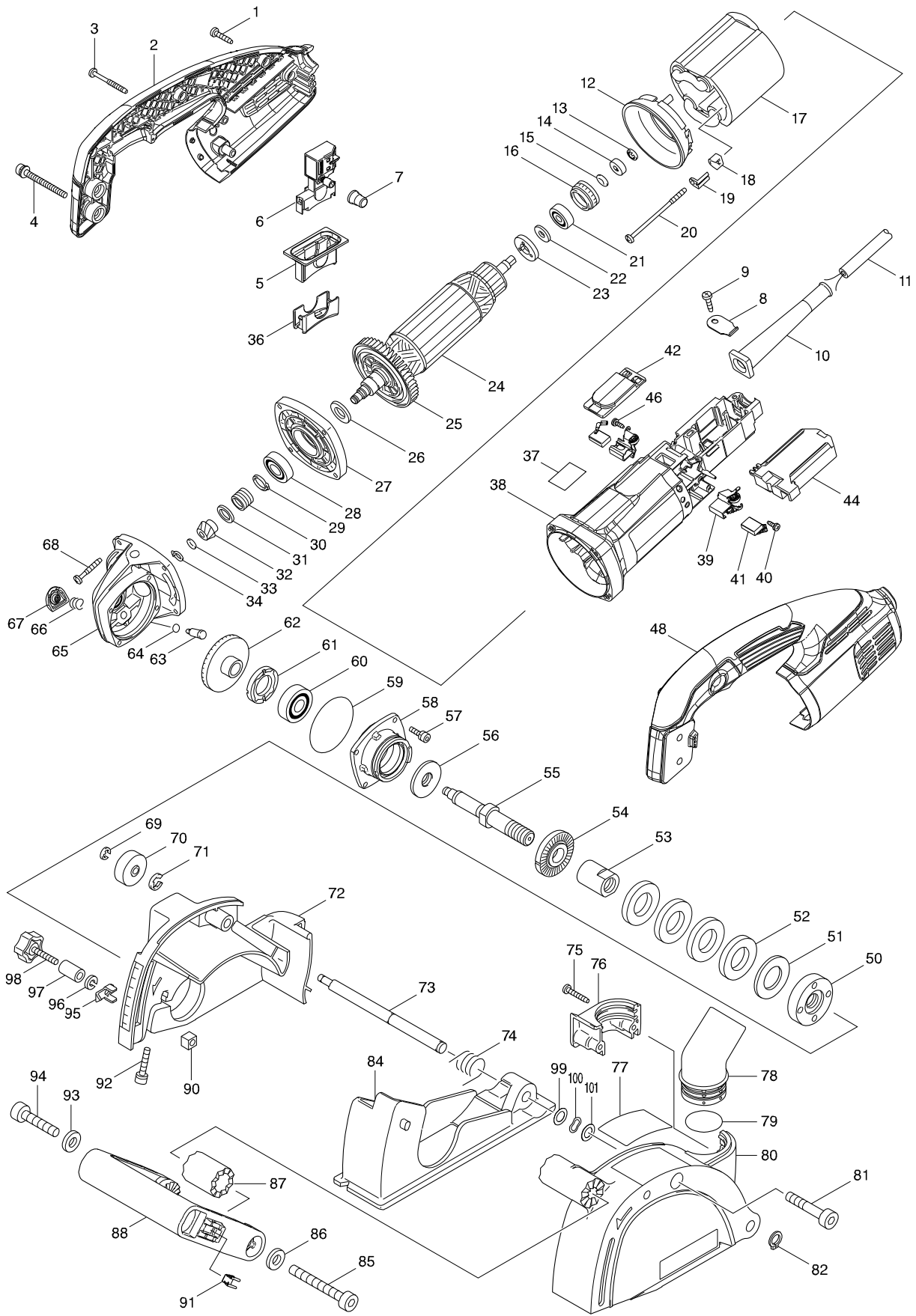

型號 SG1251 石材開槽切割機

分解圖號	零件編號	品名	交換	數量	N/O	選擇1	選擇2	註記
001	265995-6	攻牙螺絲 4X18		3				
002	187942-6	HANDLE SET		1				
D10		INC. 48						
003	266048-4	螺絲4X40		3				
004	911263-2	螺絲 M5X40		2				
005	424457-5	DUST COVER		1				
006	650113-3	SWITCH SGEL115CDY-15		1				
007	421459-2	固定鈕防塵套 F/4140		1				
008	687678-2	固定片		1				
009	266192-7	自攻螺絲 4X14		1				
010	682581-2	電線護套		1				
011	693574-4	電源線 2.0-2-5.0		1				
012	413076-2	風葉座 F/BO6040,GD0810C		1				
013	259039-2	內星狀擋圈 6		1				
014	688117-5	磁石		1				
015	267756-0	墊片 6		1				
016	421738-8	橡皮環 22		1				
017	626676-1	FIELD 115V		1				
018	417237-6	絕緣套		2				
019	344871-8	保持片		2				
020	266258-3	螺絲 4X70		2				
021	210027-4	培林627DDW		1				
022	253823-7	F 華士 7		1				
023	681656-4	絕緣華士		1				
024	515330-1	ARMATURE ASS'Y 100-110V		1				
D10		INC. 21-23,25						
025	240033-5	風葉57		1				
026	253084-9	華士 12		1				
027	317359-1	齒輪箱蓋		1				
028	210105-0	培林 6001LLU		1				
029	961052-5	擋圈 S-12		1				
030	233901-9	固定彈簧12		1				
031	253052-2	平板華士 12		1				
032	227429-7	螺旋傘齒輪 9		1				
033	253077-6	F 華士 6		1				
034	961002-0	檔圈 S-6		1				
036	452942-8	SWITCH COVER		1				
037	804W32-5	SJS MARK LABEL		1				
038	455385-3	MOTOR HOUSING		1				
039	643760-7	碳刷座 F/GD0810C,BO6040		2				
040	266256-7	自攻牙螺絲PT3X10		2				
041	191978-9	自動碳刷 CB-318		1				
042	455386-1	MOTOR HOUSING COVER		1				
044	620337-5	CONTROLLER		1				
046	266256-7	自攻牙螺絲PT3X10		2				
048	187942-6	HANDLE SET		1				
D10		INC. 2						
050	224577-3	LOCK NUT 14-45		1				

請訂購一個零件。

列印日期 2017/10/20

型號 SG1251 石材開槽切割機

分解圖號	零件編號	品名	交換	數量	N/O	選擇1	選擇2	註記
051	331661-8	SPACER 3		1				
052	331662-6	SPACER 6		4				
053	257732-2	SLEEVE 14		1				
054	224415-9	內法蘭士 42		1				
055	324393-4	SPINDLE		1				
056	415300-9	迷宮式墊圈		1				
057	265490-6	H.S.H螺絲 M4X16		4				
058	318302-3	BEARING BOX		1				
059	213673-2	O圈52 F/LS1013L		1				
060	211129-9	軸承 6201DDW		1				
061	285841-7	培林押		1				
062	227430-2	螺旋傘齒輪 35		1				
063	256459-1	鎖銷		1				
064	213048-5	O形圈 6		1				
065	153488-4	齒輪箱		1				
066	233072-2	彈簧8 F/9520B,MT950-4		1				
067	418067-8	鎖銷蓋		1				
068	266257-5	攻牙螺絲 4X18		4				
069	961011-9	擋圈 E-4		1				
070	257227-5	RING 6		1				
071	961014-3	停止圈 E-8		1				
072	153685-2	BLADE CASE COMPLETE		1				
073	324392-6	SHOULDER SHAFT		1				
074	231655-2	TORSION SPRING 11		1				
075	266040-0	螺絲 CT 4X25		2				
076	418390-1	DUST COVER		1				
077	850F04-6	SG1251 NAME PLATE		1				
078	416741-2	接頭		1				
079	213423-5	環30 F/2703		1				
080	317725-2	COVER		1				
081	922466-3	六角承窩圓柱頭螺栓 M8X45		1				
082	961006-2	擋圈 S-10		1				
084	317723-6	BASE		1				
085	922487-5	HEX. SOCKET HEAD BOLT M8X65		1				
086	941201-0	平面墊片8		1				
087	223145-9	CAM		1				
088	417665-5	FRONT GRIP		1				
090	252185-0	SQUARE NUT M6		1				
091	344391-2	起子夾座 F/62SYS,63SYS,6019		1				
092	922251-4	六角承窩圓柱頭螺栓 M5X30		1				
093	941201-0	平面墊片8		1				
094	922462-1	H.S.H.螺絲 M8X40		1				
095	345364-8	INDICATOR		1				
096	942151-2	彈性墊圈 6		1				
097	257731-4	SLEEVE 7		1				
098	251897-2	螺絲 M6X33		1				
099	253310-6	T華士 10		1				
100	267783-7	WAVE WASHER 10		1				

請訂購一個零件。

列印日期 2017/10/20

