

型號 GA7061 平面砂輪機180MM

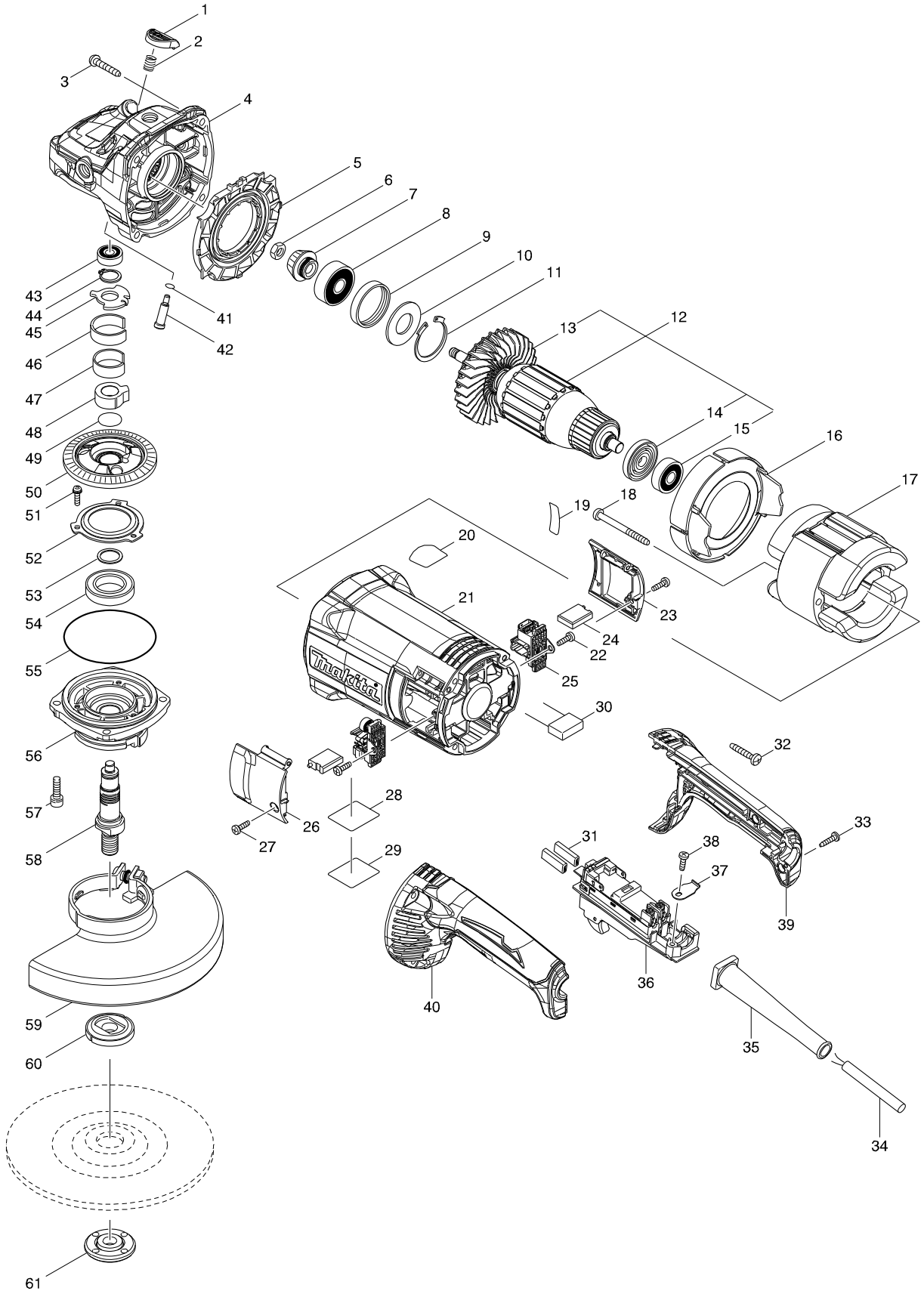

型號 GA7061 平面砂輪機180MM

分解圖號	零件編號	品名	交換	數量	N/O	選擇1	選擇2	註記
001	456247-8	銷蓋		1				
002	234391-9	彈簧 8		1				
003	251489-7	螺絲 5X30		4				
004	143485-8	齒輪座		1				
C10	263002-9	橡皮銷 4		1				
005	456238-9	擋板		1				
006	252194-9	六角螺母 M8		1				
007	227655-8	螺旋齒輪 17		1				
008	211132-0	培林 6301DDW		1				
009	262085-6	橡皮環 38		1				
010	267299-2	平板墊片 20		1				
011	962211-4	擋圈 R-42		1				
012	513446-6	ARMATURE ASS'Y 115V		1				
D10		INC. 13-15						
013	240161-6	風葉 86		1				
014	681630-2	絕緣華士		1				
015	211087-9	軸承		1				
016	456239-7	風葉座		1				
017	621776-2	FIELD 115V		1				
018	266044-2	螺絲 5X60		2				
019	851V46-9	GA7061 SERIAL NO. LABEL		1				
020	898443-6	標籤 SJS2		1				
021	456240-2	馬達座		1				
022	266385-6	螺絲4X14		2				
023	143950-7	碳刷蓋 R		1	*			
023-1	456246-0	BRUSH HOLDER COVER R	>	1				
024	197129-2	碳刷 CB-218		1				
025	643714-4	碳刷座		2	*			
025-1	643715-2	BRUSH HOLDER	<	2				
026	143949-2	碳刷蓋 L		1	*			
026-1	456245-2	BRUSH HOLDER COVER L	>	1				
027	266385-6	螺絲4X14		2				
028	851V42-7	GA7061 NAME PLATE		1				
029	808D02-2	CLEAR LABEL		1				
030	645088-9	噪音防止器		1				
031	686036-9	插座套管		2				
032	251489-7	螺絲 5X30		4				
033	266326-2	螺絲 M4X18		2				
034	693564-7	電線2-2-2.5		1				
035	682581-2	電線護套		1				
036	632F74-5	SWITCH UNIT		1	*			
036-1	632F76-1	開關元件	<	1				
037	687678-2	固定片		1				
038	266385-6	螺絲4X14		1				
039	183C63-0	手柄組		1				
D10		INC. 40						
040	183C63-0	手柄組		1				
D10		INC. 39						

請訂購一個零件。

列印日期 2017/10/27

型號 GA7061 平面砂輪機180MM

分解圖號	零件編號	品名	交換	數量	N/O	選擇1	選擇2	註記
041	213026-5	O 形環 7		1				
042	256571-7	肩銷 7		1				
043	211032-4	培林 608ZZ		1				
044	961055-9	檔圈 S-15		1				
045	346980-9	平衡器		1				
046	346981-7	C型板 33		1				
047	346982-5	C型板 29		1				
048	326640-9	接合套		1				
049	213859-8	O圈 19		1				
050	227657-4	螺旋齒輪 55		1				
051	911128-8	平頭螺絲 4X16		3				
052	285742-9	軸承保持器 59		1				
053	253725-7	FLAT WASHER 17		1				
054	211377-0	培林6905LLB		1				
055	213760-7	O圈 78		1				
056	143515-5	軸承箱		1				
057	265541-5	六角螺絲 M6X22		4				
058	326641-7	主軸		1				
059	123474-9	WHEEL COVER 180TK ASSEMBLY		1				
C10	213017-6	O圈 6		1				
C20	265198-2	#NAME?		1				
C30	806X80-6	CAUTION LABEL		1				
060	224481-6	內法蘭士 45		1				
061	224485-8	鎖定螺母 14-45		1				
A01	143486-6	齒輪 37		1				
A02	782407-9	油蓋板手 35		1				