

型號 GA5021C 平面砂輪機125MM

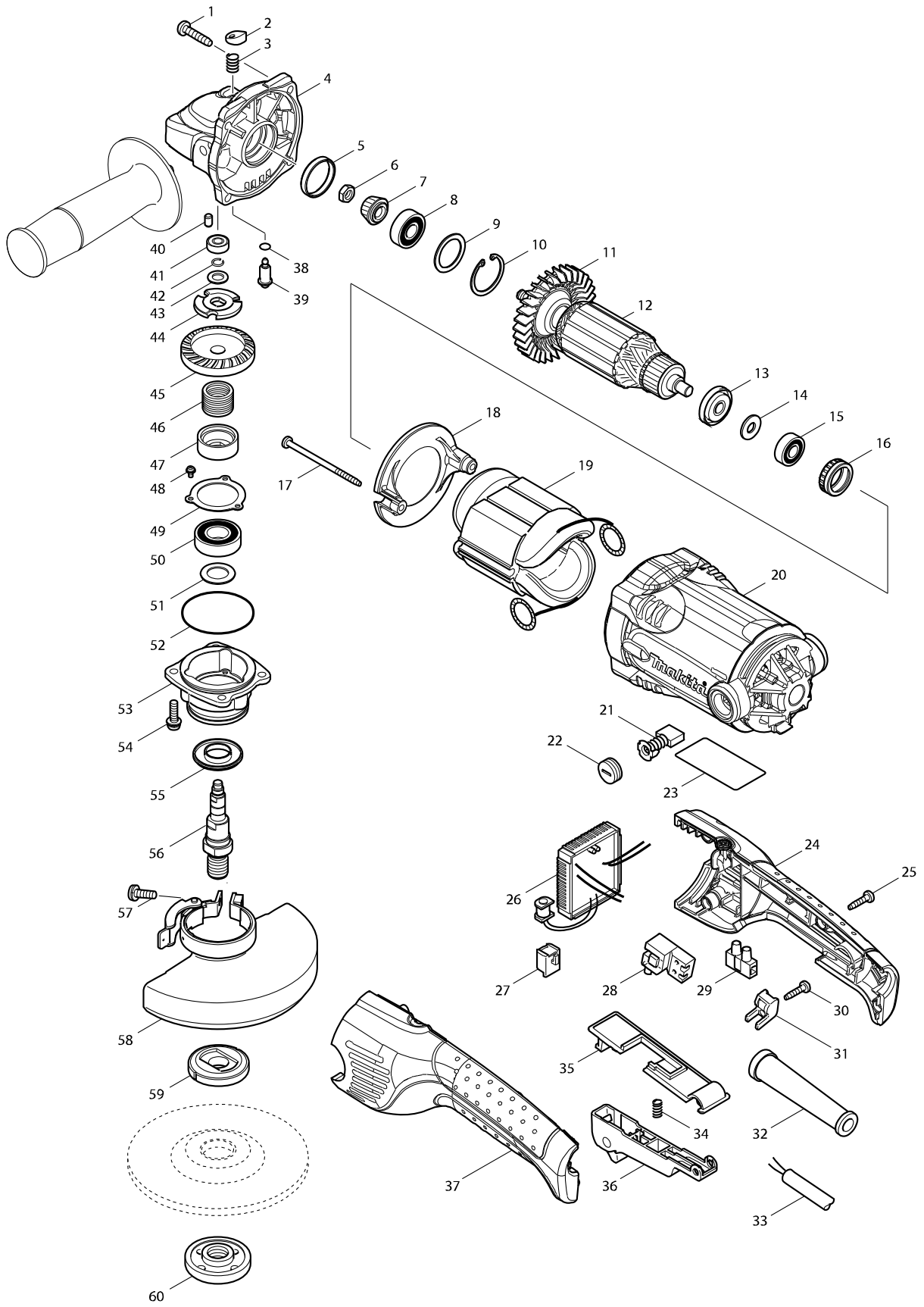

型號 GA5021C 平面砂輪機125MM

分解圖號	零件編號	品名	交換	數量	N/O	選擇1	選擇2	註記
001-1	266459-3	自攻螺絲 5X25		4				
002	417771-6	銷蓋		1				
003	234057-1	扭力彈簧 8		1				
004	318158-4	齒輪箱 F/GA5020		1				
005	424051-3	RUBBER RING 26		1				
006	264010-3	六角螺母M7		1				
007	227520-1	傘型齒輪11		1				
008-1	210059-1	滾珠軸承 6000DDW		1				
009	267352-4	平板華士22 F/GA5020		1				
010	962107-9	擋圈R-30		1				
011	240094-5	風葉70		1				
012-2	518689-5	馬達心 115V F/GA6021C		1				
D10		INC. 11,13-15						
013	681660-3	絕緣墊圈 F/GV&PV7000C		1				
014	267281-1	平墊圈 8		1				
015-1	210005-4	軸承 608DW		1				
016	421720-7	橡皮圈 15		1				
017	266325-4	螺絲 4X70		2				
018	419961-7	風葉座 F/GA5020		1				
019	528810-8	FIELD ASS'Y 115V		1				
C10	654020-2	碳刷座圈 CB-5		2				
C20	654501-6	連接頭 P-1.25		2				
020	158398-0	MOTOR HOUSING COMPLETE		1				
C10	643751-8	碳刷座 F/4100NB,JR3020		2				
021	194547-5	碳刷CB-253 F/GA5021C		1				
022	643750-0	碳刷座蓋		2				
023	864047-6	GA5021C NAME PLATE		1				
024	187645-2	HANDLE SET		1				
D10		INC. 37						
025	266326-2	螺絲 M4X18		4				
026	631797-6	CONTROLLER		1				
027	418518-1	套		1				
028-2	651922-3	啟動開關		1				
029	654575-7	接線端子		1				
030	266326-2	螺絲 M4X18		2				
031	687149-9	電線固定片		1				
032	682575-7	電線保護套		1				
033	693564-7	電線2-2-2.5		1				
034	233117-6	彈簧 6		1				
035	418519-9	開關座		1				
036	158402-5	SWITCH LEVER B COMPLETE		1				
037	187645-2	HANDLE SET		1				
D10		INC. 24						
038	213977-2	O圈7 F/GA5020		1				
039	256505-0	固定銷5		1				
040	263002-9	橡皮銷 4		1				
041	210006-2	滾珠軸承 696ZZ		1				
042	233926-3	彈簧7 F/GA5020		1				

請訂購一個零件。

列印日期 2017/11/17

型號 GA5021C 平面砂輪機125MM

分解圖號	零件編號	品名	交換	數量	N/O	選擇1	選擇2	註記
043	253835-0	平面墊片 8		1				
044	267811-8	固定墊片 F/GA5020		1				
045	227522-7	齒輪35B F/GA6020		1				
046	233957-2	彈簧16 F/GA5020		1	*			
046-1	234356-1	彈簧16	<	1				
047	324833-2	彈簧座 F/GA5020		1				
048	911003-8	螺絲 M3X6		3				
049	285728-3	軸承保持片39		1				
050	211236-8	軸承6002DDW		1				
051	253853-8	F 華士15 C/267280-3		1				
052	213624-5	○圈48 F/GA5020		1				
053-1	318299-6	軸承箱C/318332-4 F/GA50,60		1				
054	265131-4	螺絲M5X18		4				
055	345464-4	內圈		1				
056	324789-9	車心 F/GA5020		1				
057	251391-4	盤頭螺釘 M5×16		1				
058	135108-2	TOOLLESS WHEEL COVER 125 ASS'Y		1	*			
D10		INC. 57			*			
058-1	123514-3	TOOLLESS WHEEL COVER 125T ASSY	X	1				
C10	806X78-3	CAUTION LABEL		1				
D10		INC. 57						
059	224415-9	內法蘭士 42		1	*			
059-1	224481-6	內法蘭士 45	<	1				
060	224554-5	外法蘭士14-45		1				
061	253828-7	F華士 10		1				
A01	162258-0	防震把手		1				
A02	782423-1	板手35		1				
A03	801R41-5	GA5021C01 CARTON LABEL		1				

請訂購一個零件。

列印日期 2017/11/17