

型號 DVC861L 充電式集塵機-單機18Vx2 乾式專用

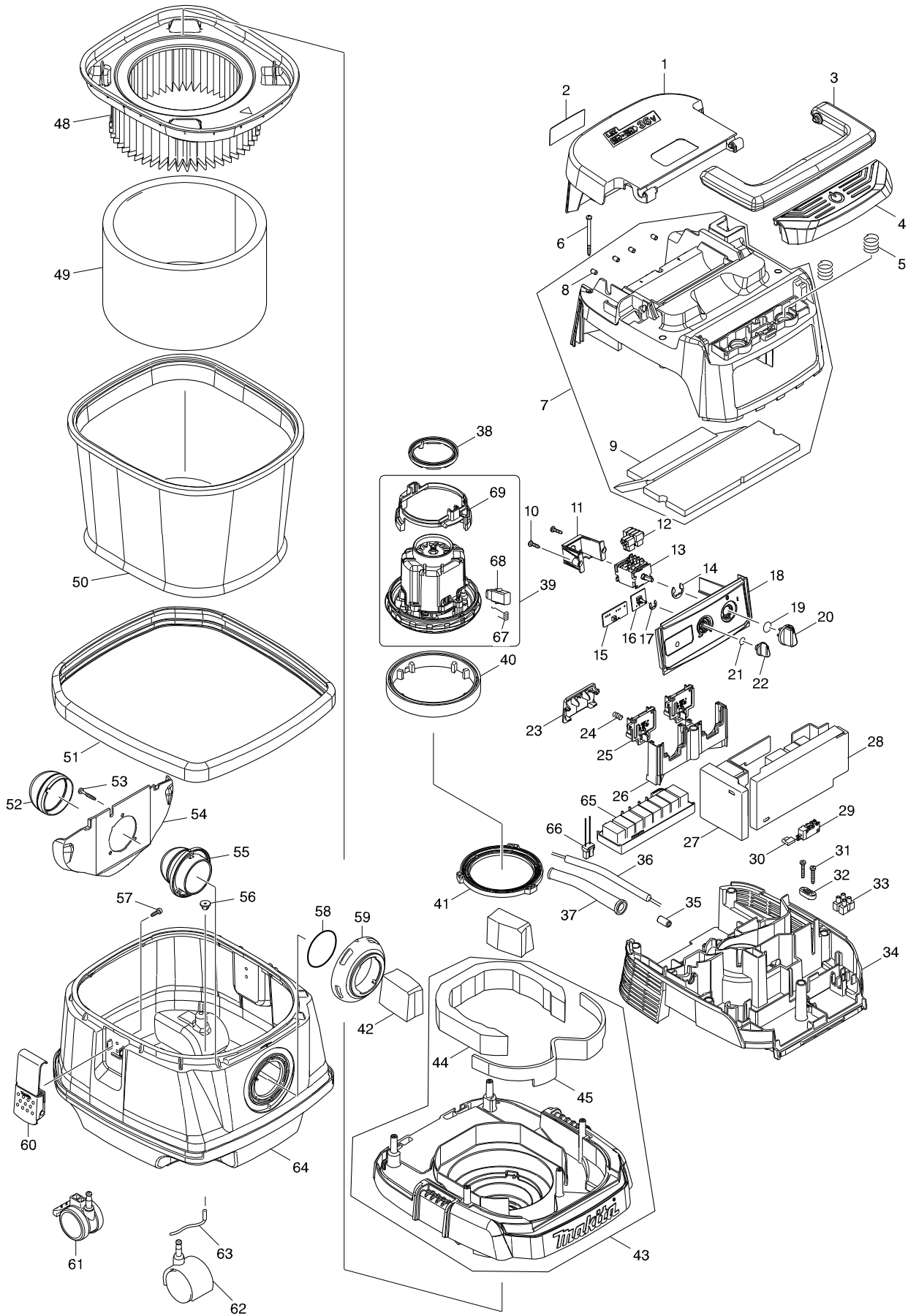

型號 DVC861L 充電式集塵機-單機18Vx2 乾式專用

分解圖號	零件編號	品名	交換	數量	N/O	選擇1	選擇2	註記
001	143174-5	電池蓋		1	*			
001-1	144486-9	BATTERY COVER COMPLETE	<	1				
002	851W61-9	DVC861L NAME PLATE		1				
003	455734-4	握把		1				
004	455730-2	開關按鈕		1				
005	234273-5	COMPRESSION SPRING 20		2				
006	266340-8	螺絲 4X65		6				
007	143173-7	外罩組		1				
D10		INC. 8,9						
008	263005-3	橡皮銷 6		4				
009	424688-6	TOP DAMPER		1				
010	266326-2	螺絲 M4X18		2				
011	451343-7	開關固定座		1				
012	686023-8	插座套		6				
013	650745-6	開關		1				
014	961062-2	擋圈 F/M925		1				
015	620394-3	LED電路		1				
016	631922-9	控制座		1				
017	961013-5	停止圈 E-7		1				
018	143176-1	開關基座		1				
019	213176-6	O圈 14		1				
020	455733-6	開關桿		1				
021	213054-0	O圈 9 F/HM1302		1				
022	451344-5	開關旋鈕		1				
023	455728-9	電池蓋鉤		1				
024	231240-1	扭力彈簧7		1				
025	644808-8	電池端子		2				
026	455729-7	端子基座		1				
027	620393-5	控制器B		1				
028	620391-9	控制器A		1				
029	651910-0	SWITCH D2VW-01-3HS		1				
030	686039-3	接線端子		2				
031	266374-1	螺絲 4X25		2				
032	687140-7	電線固定片		1				
033	654561-8	接頭組 F/2012NB		1				
034	455726-3	分離器		1				
035	688161-2	濾波器		1	*			
035-1	688163-8	LINE FILTER	<	1				
036	693535-4	電源線		1				
037	682584-6	導線保護裝置		1				
038	424685-2	橡膠圈60		1				
039	629155-8	馬達組件		1	*			
D10		INC. 67-69			*			
039-1	629338-0	MOTOR ASSEMBLY	<	1				
D10		INC. 67-69						
040	424686-0	橡膠圈120		1				
041	424687-8	座圈		1				
042	424690-9	後座過濾器		2				

請訂購一個零件。

列印日期 2017/09/11

型號 DVC861L 充電式集塵機-單機18Vx2 乾式專用

分解圖號	零件編號	品名	交換	數量	N/O	選擇1	選擇2	註記
043	143175-3	集塵蓋		1				
D10		INC. 44,45						
044	424691-7	BAND DAMPER		1				
045	424689-4	FRONT DAMPER		1				
048	197166-6	粉塵濾芯組		1				
049	423398-2	阻尼器		1				
050	140253-0	過濾袋		1				
051	424230-3	緩衝環		1				
052	424382-0	橡膠套		1				
053	266257-5	攻牙螺絲 4X18		3				
054	419351-4	支架板		1				
055	419350-6	支架		1				
056	421468-1	繩子塞		1				
057	266192-7	自攻螺絲 4X14		4				
058	213655-4	O圈 56		1				
059	451348-7	進氣環		1				
060	168537-4	固定扣		2				
061	168535-8	輪子		2				
062	168434-4	輪子		2				
063	649150-2	排電線120 F/406		1				
064	451334-8	集塵箱		1	*			
064-1	457623-9	TANK	<	1				
065	620502-6	控制器		1				
066	632F97-3	引線單元		1				
067	DM46312612	碳刷彈簧		2				
068	197207-8	碳刷組		1	*			
068-1	198998-4	CARBON BRUSH SET CB-354	<	1				
069	DM46714602	碳刷架		1				
A01	122512-4	集塵頭組 F/406,404X		1				
C01	151449-8	ROLLER 40 COMPLETE		2				
C06	415962-3	ROLLER 14		2				
C11	256241-8	PIN 3		2				
C16	265871-4	螺絲 M4X16		6				
C21	154427-7	ELBOW JOINT COMPLETE		1				
C26	415965-7	UPPER NOZZLE		1				
C31	415964-9	JOINT HOLDER		1				
C36	743328-0	BRUSH		1				
C41	743327-2	WIPER		1				
A02	195434-1	集塵管38-3.5		1	*			
A02-1	195434-1	集塵管38-3.5	O	1				
C20	417191-4	袖口鎖		1				
C30	417306-3	SLEEVE		2				
C40	417307-1	FRONT CUFF		1				
C50	417586-1	塞		2				
A03	195432-5	聚合袋組(每組10片)		1				
A04	192563-1	直管		1				
A05	192562-3	彎管		1				
A06	410306-2	角落吸嘴		1				

請訂購一個零件。

列印日期 2017/09/11

型號 DVC861L 充電式集塵機-單機18Vx2 乾式專用

分解圖號	零件編號	品名	交換	數量	N/O	選擇1	選擇2	註記
A07	451350-0	塞子		1				
A08	455732-8	TOOL BOX		1				
A09	911138-5	螺絲 M4X20		1				
A11	195433-3	集塵管28-3.5		1	*			
C10	417765-1	前面環口 22		1	*			
C20	424379-9	前面環口 24		1	*			
A11-1	195433-3	集塵管28-3.5	O	1				
C10	417765-1	前面環口 22		1				
C20	424379-9	前面環口 24		1				
C30	417191-4	袖口鎖		1				
C40	417586-1	塞		1				
C50	417662-1	套管		1				
C60	417766-9	FRONT CUFF 38		1				

請訂購一個零件。

列印日期 2017/09/11