

型號 EW1050H 引擎式幫浦4ST/24.5CC

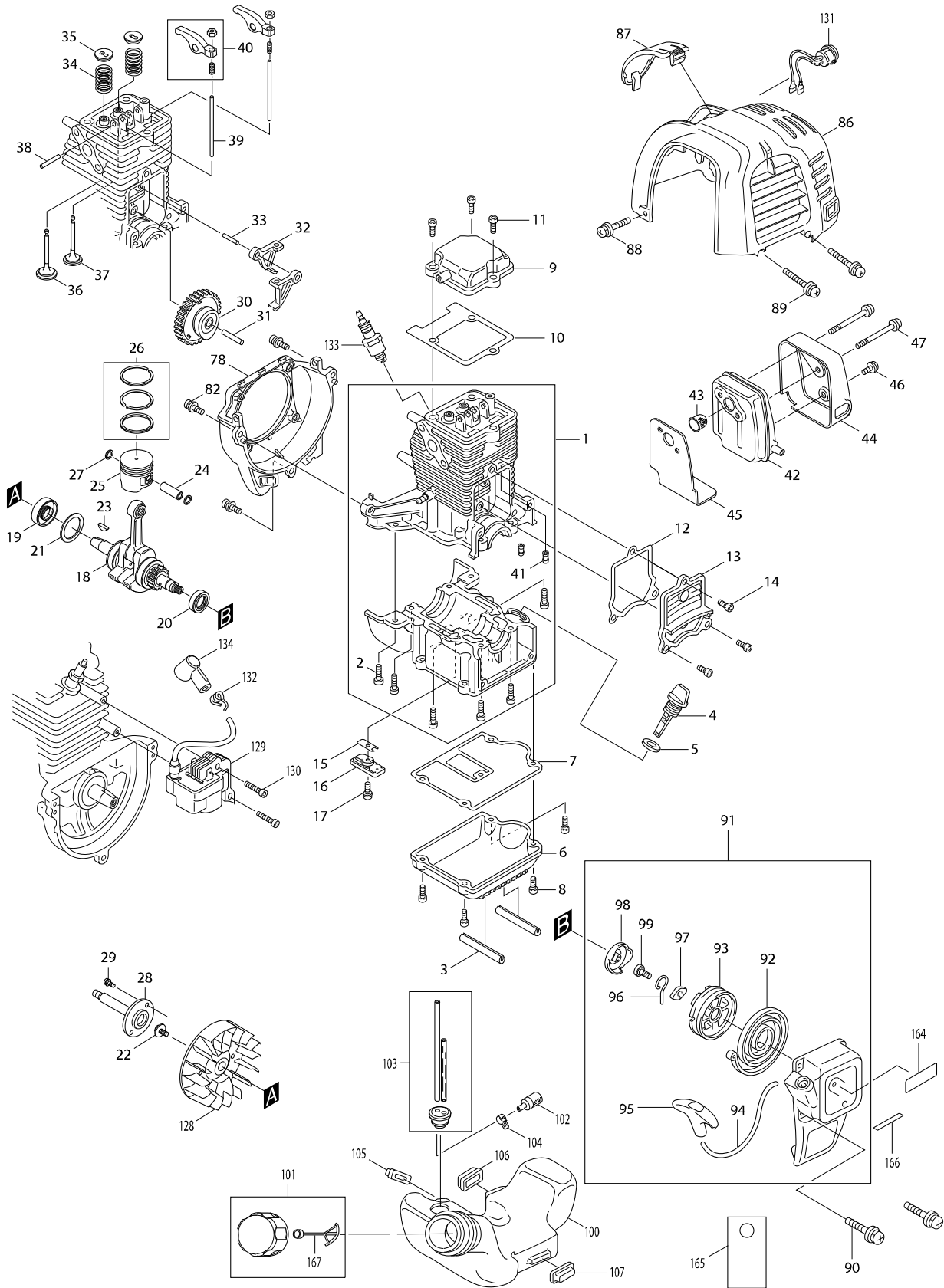

型號 EW1050H 引擎式幫浦4ST/24.5CC

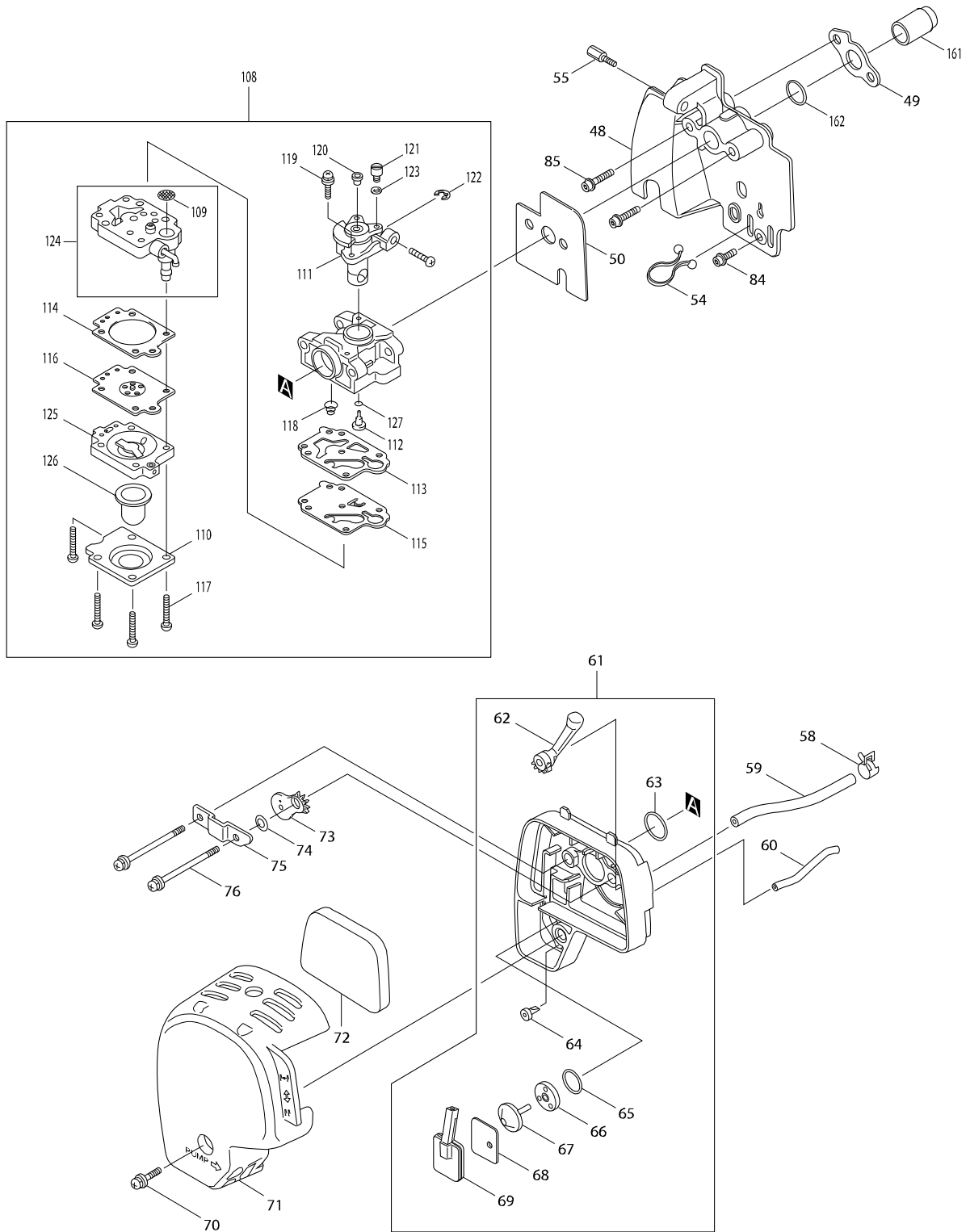

型號 EW1050H 引擎式幫浦4ST/24.5CC

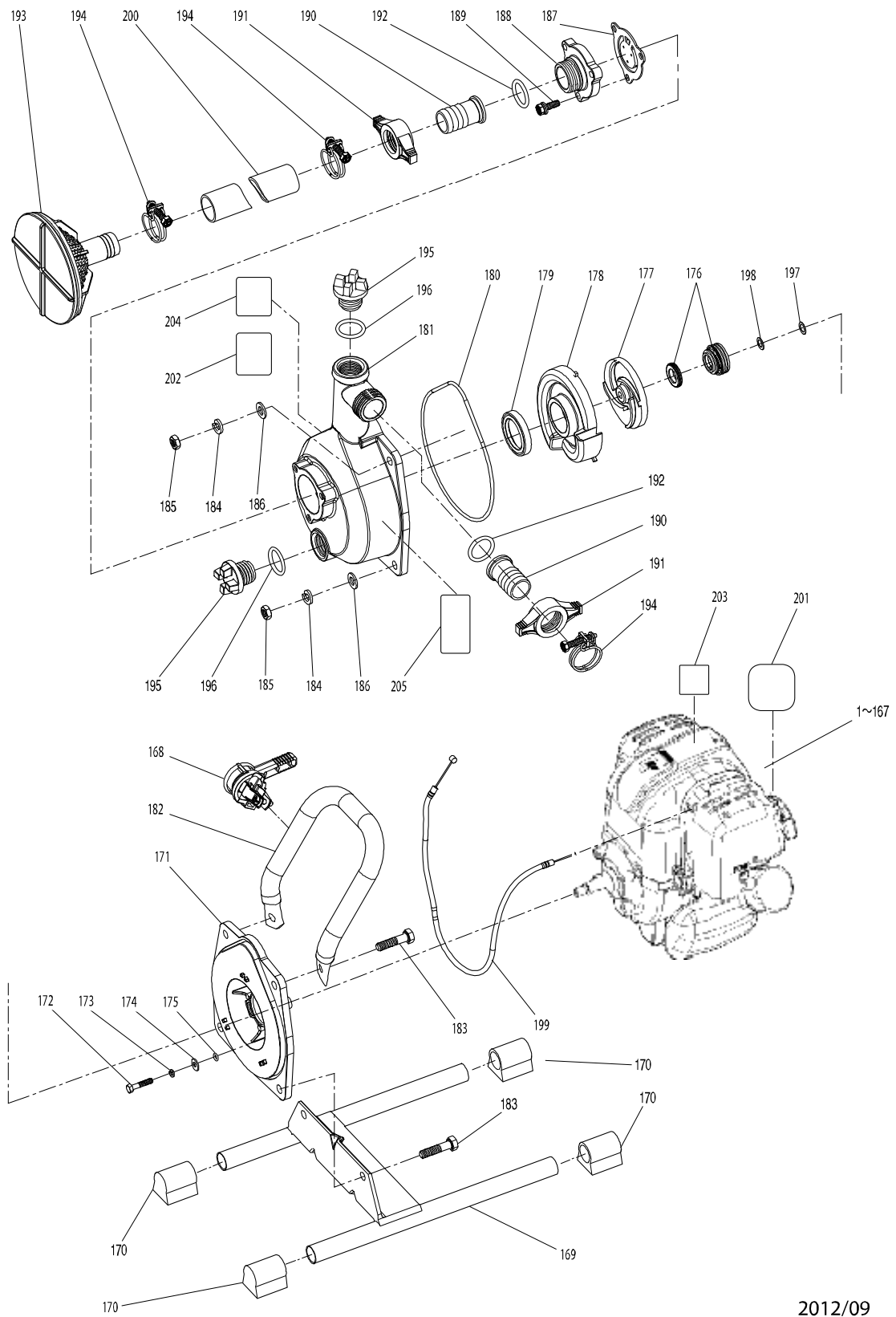

2012/09
EW1050H 3/3

型號 EW1050H 引擎式幫浦4ST/24.5CC

分解圖號	零件編號	品名	交換	數量	N/O	選擇1	選擇2	註記
001	135562-0	缸體總成		1				
D10		INC. 2,41						
002	922217-4	H.S.H.螺絲 M5X14		8				
003	424530-1	油箱防護物		2				
004	450565-6	油標尺		1				
005	424100-6	墊片		1				
006	318442-7	油箱		1				
007	162276-8	箱襯墊		1				
008	922217-4	H.S.H.螺絲 M5X14		4				
009	140023-7	搖臂外蓋組件		1				
010	162275-0	搖臂外蓋襯墊		1				
011	922222-1	螺栓 M5X16		3				
012	162274-2	凸輪蓋襯墊		1				
013	318443-5	凸輪齒輪蓋		1				
014	922217-4	H.S.H.螺絲 M5X14		3				
015	346083-9	引導閥		1				
016	318440-1	固定板		1				
017-1	922112-8	螺栓 M4X10		1				
018	126299-0	曲軸總成		1				
019	213147-3	油封 12		1	*			
019-1	213089-1	OIL SEAL 12	<	1				
020	213148-1	油封 10		1	*			
020-1	213769-9	油封 10	<	1				
021	267400-9	平墊片 23		1				
022	265577-4	六角螺栓 M6X16		1				
023	254040-2	半圓鍵 3		1				
024	257781-9	活塞銷		1				
025	318441-9	活塞		1				
026-1	196595-0	活塞環組		1				
027	233976-8	固定夾		2				
028	326223-5	軸		1				
029	911323-0	螺絲 M6X16		2				
030	125552-1	凸輪組		1				
031	268238-5	插銷 5		1				
032	313169-4	凸輪升桿		2				
033	268239-3	插銷 4		1				
034	234108-0	壓縮彈簧 9		2				
035	325668-4	彈簧扣件		2				
036-1	326367-1	進氣閥		1				
037-1	326366-3	排氣閥		1				
038	256200-2	插銷 5		1				
039	256865-0	橫桿 2.5		2				
040	125554-7	搖臂		2				
041	424200-2	隔片		2				
042	168469-5	排氣消音器		1				
043	324980-9	火星網		1				
044	345915-7	消音器外蓋		1				
045	345916-5	消音器襯墊		1				

請訂購一個零件。

列印日期 2017/11/17

型號 EW1050H 引擎式幫浦4ST/24.5CC

分解圖號	零件編號	品名	交換	數量	N/O	選擇1	選擇2	註記
046	265184-3	十字圓頭螺絲M5X5		1				
047	266440-4	螺栓 M5X40		2				
048	450559-1	絕緣體		1				
049	413120-5	絕緣體襯墊		1				
050	413121-3	化油器襯墊		1				
054	450562-2	固定夾		1				
055	325934-9	調節螺桿		1				
058	345918-1	軟管夾		1				
059	422041-0	通氣管		1				
060	422042-8	管路		1				
061	125468-0	清潔板組		1				
D10		INC. 62-69						
062	451925-5	阻流桿		1				
063	213540-1	O 形環 15		1				
064	424316-3	止回閥		1				
065	213539-6	O 形環 14		1				
066	451924-7	止回閥板		1				
067	424315-5	止回閥		1				
068	168577-2	分離器襯墊C/5923503500		1				
069	168576-4	分離器板		1				
070	911218-7	盤頭螺絲 M5X14		1				
071	450561-4	空氣濾清器蓋		1				
072	443141-3	空氣濾清器濾芯		1				
073	450560-6	阻流板		1				
074	423376-2	襯墊		1				
075	345919-9	固定板		1				
076	265188-5	盤頭螺絲 M5X68		2				
078	141766-4	鼓風機外殼		1				
082	922223-9	H.S.H.螺絲 M5X16		3				
084	922213-2	螺栓 M5X12 (W, WR) WR)		1				
085	922228-9	內六角螺絲 M5X18		2				
086	450564-8	缸蓋		1				
087	452144-6	火花塞罩		1				
088	911213-7	螺絲M5X12		2				
089	911128-8	平頭螺絲 4X16		2				
090	911128-8	平頭螺絲 4X16		2				
091	195146-6	反沖啟動器組		1				
D10		INC. 92-99						
092	232258-5	螺旋彈簧		1				
093	451937-8	捲軸		1				
094	444019-3	啟動器繩		1				
095	424319-7	啟動器握把		1				
096	325923-4	擺臂		1				
097	451938-6	軸環		1				
098	168483-1	滑輪		1				
099	266585-8	螺絲 5X12		1				
100	450566-4	燃料箱		1				
101	125472-9	燃油箱蓋組		1				

請訂購一個零件。

列印日期 2017/11/17

型號 EW1050H 引擎式幫浦4ST/24.5CC

分解圖號	零件編號	品名	交換	數量	N/O	選擇1	選擇2	註記
D10		INC. 167						
102	163447-0	燃油濾清器		1	*			
102-1	163447-0	燃油濾清器	O	1				
103	168472-6	管		1				
104	345920-4	軟管夾		1				
105	424102-2	固定板		1				
106	424103-0	固定板		1				
107	424104-8	阻尼器		1				
108	168781-3	化油器		1				
D10		INC. 110,113-119,121-127						
109-1	WJ00014070	過濾網		1				
110	346270-0	油幫浦外蓋		1				
113	442155-9	幫浦襯墊		1				
114	442154-1	計量隔板襯墊		1				
115	168575-6	膜片		1	*			
115-1	WJ00009599	幫浦隔板	O	1				
116	168574-8	計量隔板		1	*			
116-1	WJ00963279	SCREW	O	1				
117	266582-4	螺絲 3X24		4				
118	234183-6	錐形壓縮彈簧 5-9		1				
119-1	WJ00096364	螺絲		2				
121	325922-6	轉環		1				
122	257964-1	止動環 E-3		1				
123	413140-9	墊片		1				
124	140437-0	幫浦主體		1				
125	140438-8	空氣清除主體		1				
126	424314-7	注油幫浦		1				
127	213538-8	O 形環 2		1				
128	318702-7	飛輪		1	*			
128-1	319205-4	FLYWHEEL	O	1				
129	168501-5	點火線圈		1	*			
129-1	168816-0	IGNITION COIL	S	1				
130	266602-4	螺栓 M4X20		2				
131	126240-3	停止開關總成		1	*			
131-1	141794-9	STOP SWITCH COMPLETE	S	1				
132	324891-8	火星塞帽彈簧		1				
133	168401-9	火星塞		1				
134	424105-6	塞蓋		1				
161	324961-3	進氣管		1				
162	213078-6	O圈10		1				
163	424201-0	止回閥		2				
165	819432-8	警告標籤		1				
166	897794-4	SERIAL NO. LABEL		1				
167	140436-2	繩帶總成		1				
168	ME08121070	加油柄組		1				
169	ME00204835	層架組		1				
170	ME01676311	橡膠腳墊		4				
171	ME08121002	泵座		1				

請訂購一個零件。

列印日期 2017/11/17

型號 EW1050H 引擎式幫浦4ST/24.5CC

分解圖號	零件編號	品名	交換	數量	N/O	選擇1	選擇2	註記
172	ME01676313	六角螺栓		4				
173	ME00200115	圈		4				
174	ME01676314	墊片		4				
175	ME01676315	O型圈		4				
176	ME00200486	機械油封		1				
177	ME08121003	葉輪		1				
178	ME08121004	蝸殼		1				
179	ME01676319	密封環		1				
180	ME01676320	O圈		1				
181	ME08121005	泵殼		1				
182	ME08121006	手柄		1				
183	ME00200116	六角螺栓 M8x35		4				
184	ME00200117	墊料		4				
185	ME01676323	六角螺帽		4				
186	ME00200091	平面墊片		4				
187	ME08121007	閥門		1				
188	ME08121008	螺栓連結 G1		1				
189	ME00200011	六角螺栓 M6x20		3				
190	ME01676327	連結管		2				
191	ME08121009	螺母		2				
192	ME08121044	密封圈		2				
193	ME01689268	濾器組		1				
194	ME01676330	籬		3				
195	ME01676331	水控裝置		2				
196	ME01676329	O圈		2				
197	ME01676333	墊片		99				
198	ME01676334	墊片		99				
199	ME08121010	油門線		1				
200	ME01676336	吸水管		1				
201	ME08121001	NOTE LABEL		1				
202	ME08121012	NOTE LABEL		1				
203	ME08121030	注意標籤		1				
204	ME08121035	注意標籤		1				
205	ME03333192	注意標籤		1				
206	632B57-1	LEAD UNIT	S	2				
A01	ME08121017	套筒板手		1				
A02	ME08121040	快速接頭組		1	*			
D10		INC. A03,A04			*			
A02-1	ME08121040	快速接頭組	<	2				
D10		INC. A03,A04						
A03	ME08121044	密封圈		1				
A04	ME08121045	密封圈		1				
A05	ME08121051	連接件芯		1	*			
D10		INC. A06,A07			*			
A05-1	ME08121051	連接件芯	O	1				
A06	ME08121052	接頭螺母		1				
A07	ME08121044	密封圈		1				
A08	ME08121053	籬		1				

請訂購一個零件。

列印日期 2017/11/17

