

型號 EM4350UH 引擎割草機4ST/43CC

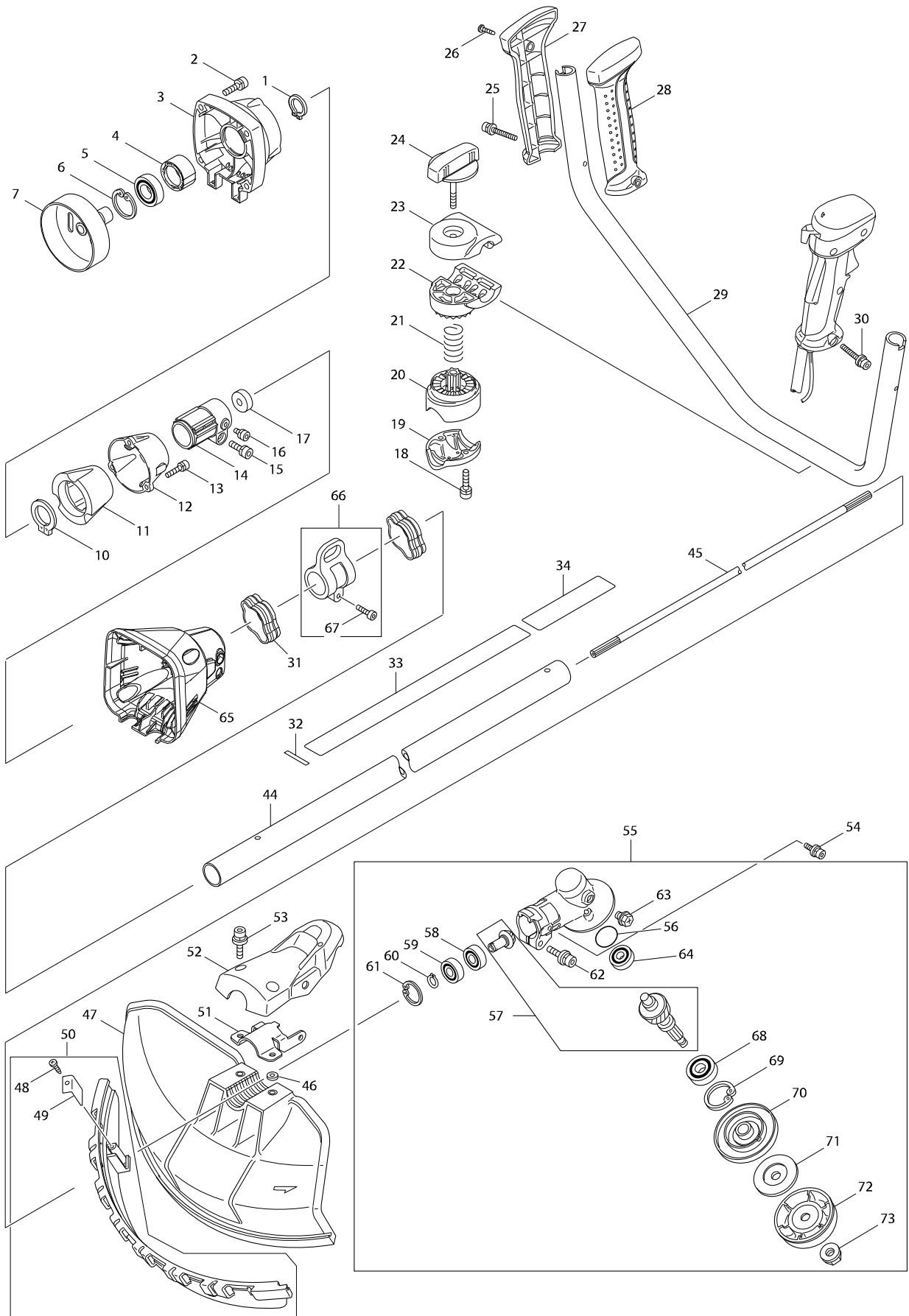

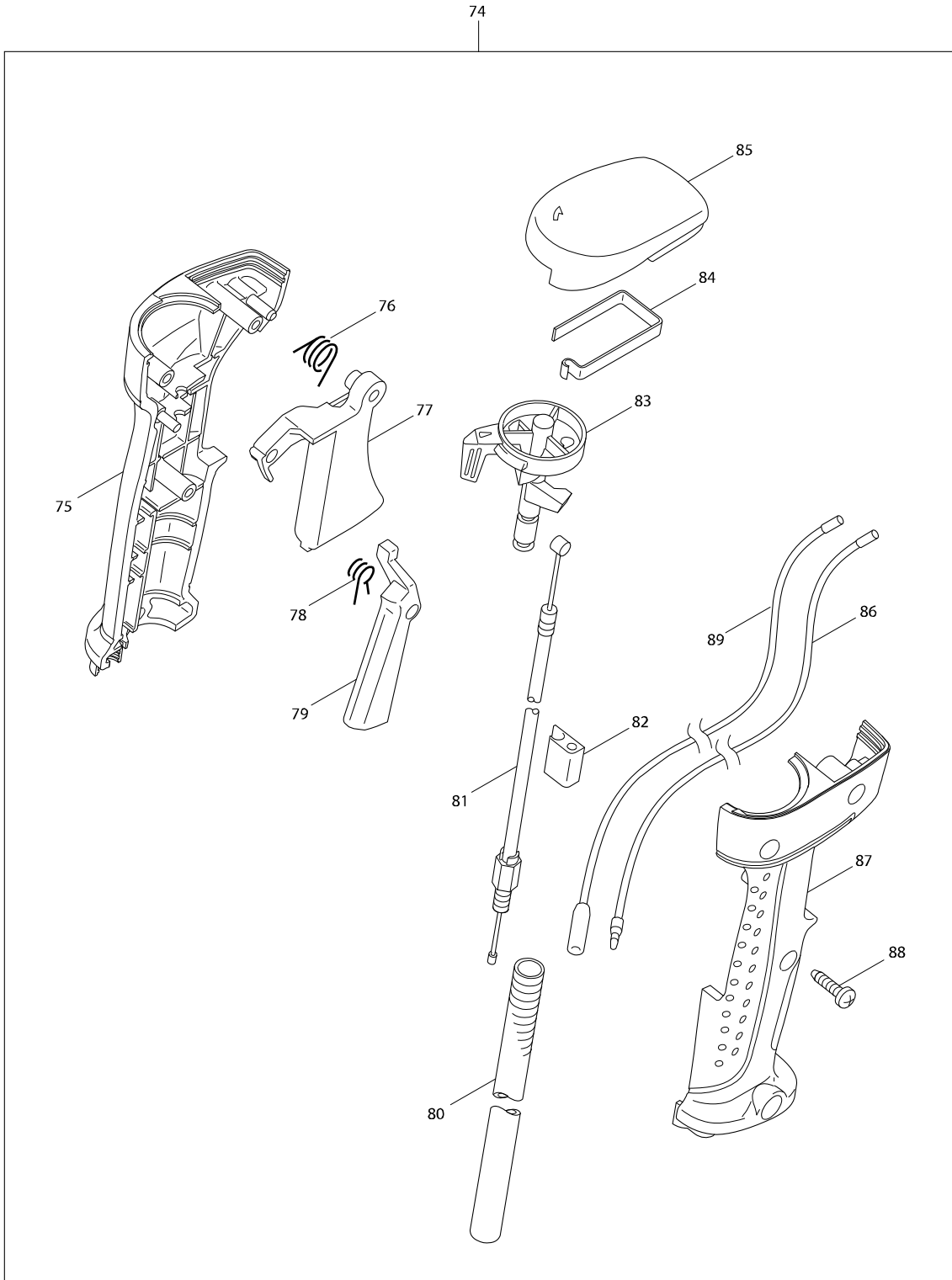

型號 EM4350UH 引擎割草機4ST/43CC

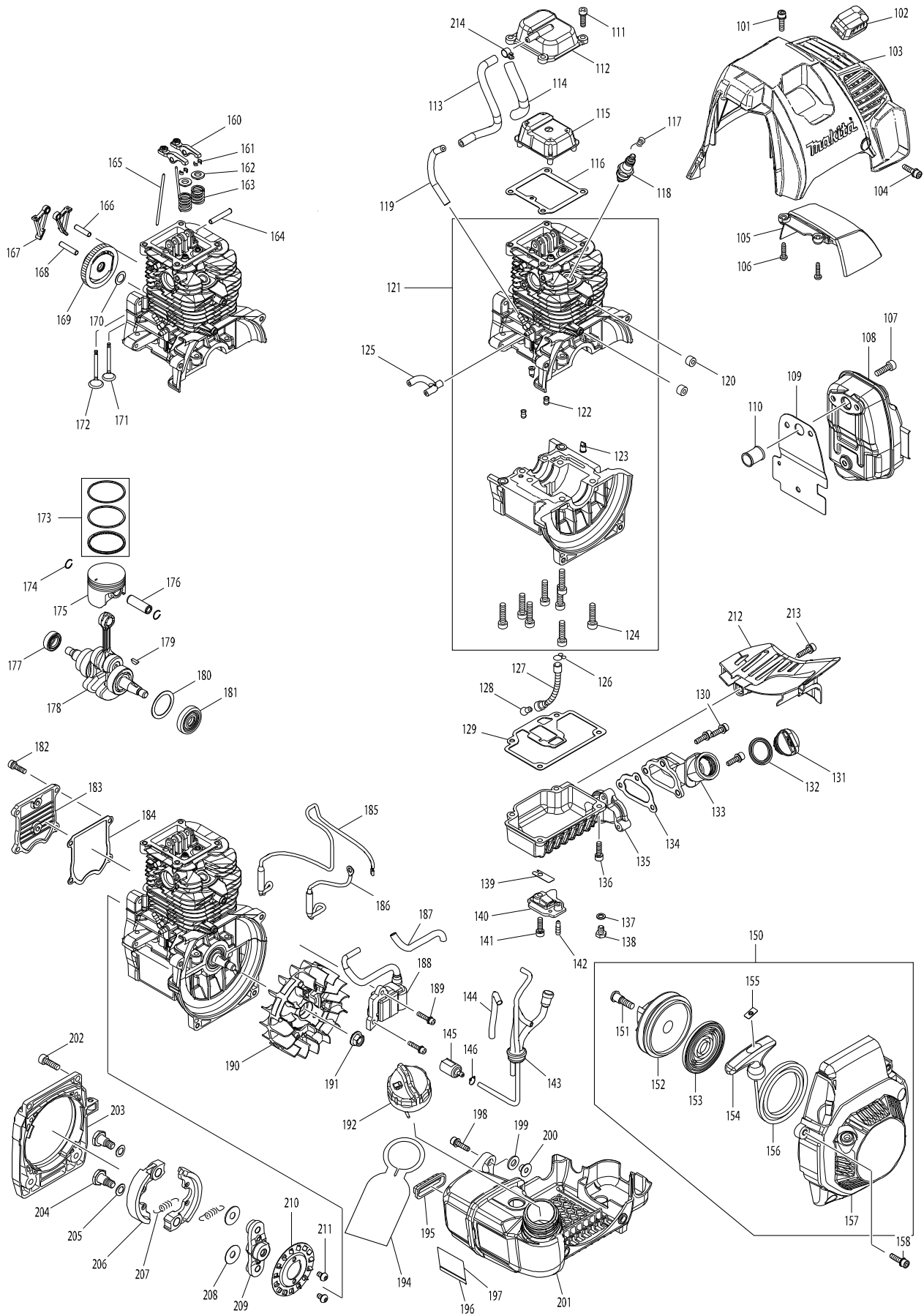

型號 EM4350UH 引擎割草機4ST/43CC

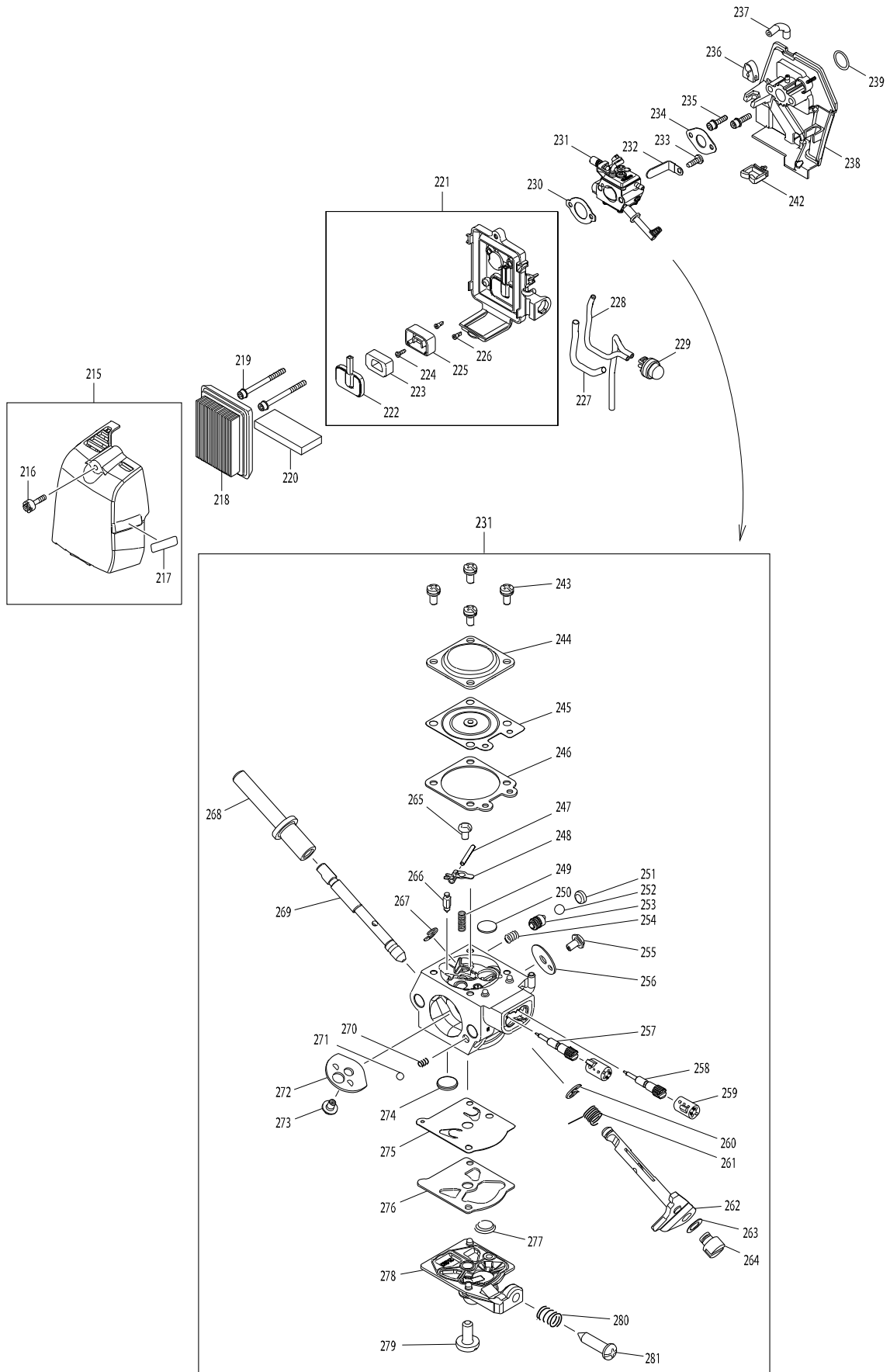

型號 EM4350UH 引擎割草機4ST/43CC

分解圖號	零件編號	品名	交換	數量	N/O	選擇1	選擇2	註記
001	961057-5	擋圈 S-17		1				
002	922331-6	H.S.H.螺絲 M6X20		4				
003	318421-5	離合器殼		1				
004	451157-4	間隔柱		1				
005	210138-5	培 6003LLU		1	*			
005-1	211338-0	培林 6003 LLU	O	1				
006	962153-2	擋圈R-35		1				
007	168742-3	CLUTCH DRUM		1				
010	961151-3	擋圈S-32 C/961171-7		1				
011	424204-4	DAMPER		1				
012	318453-2	PIPE RETAINER		1				
013	922231-0	H.S.H.螺絲 M5X20		3				
014	318454-0	PIPE BRACKET		1				
015	922331-6	H.S.H.螺絲 M6X20		1				
016	922201-9	六角螺絲M5X8 F/LC1210,JR3020		1				
017	443146-3	FELT RING 8		1				
018	922341-3	H.S.H.螺絲 M6X25		2				
019	318422-3	管夾		1				
020	318423-1	管座		1				
021	233202-5	扭力彈簧 20		1				
022	318424-9	握把座		1				
023	318425-7	握把夾座		1				
024	168796-0	旋鈕 57		1				
025	911256-9	盤頭螺絲 M5X35		1				
026	266326-2	螺絲 M4X18		1				
027	188660-9	把手組		1				
D10		INC. 28						
028	188660-9	把手組		1				
D10		INC. 27						
029	331863-6	握把 22		1				
030	911256-9	盤頭螺絲 M5X35		1				
031	451525-1	WIRE CLAMP		2				
032	814K97-7	SERIAL NO. LABEL		1				
033	898821-0	CAUTION LABEL		1	*			
033-1	802Y98-1	CAUTION LABEL	O	1				
034	819312-8	MAKITA 標誌標籤		1				
044	140042-3	SHAFT PIPE COMPLETE		1				
045	325675-7	軸		1				
046	413143-3	墊片		2				
047	452259-9	PROTECTOR		1				
048	266326-2	螺絲 M4X18		1				
049	346074-0	裁刀		1				
050	135398-7	保護器延伸總成		1				
D10		INC. 48,49						
051	346072-4	PROTECTOR CLAMP		1				
052	451090-0	PROTECTOR COVER		1				
053	266579-3	螺栓 M6X30		2				
054	266865-2	H.S.H.BOLT M5X14 WITH WR		2				

請訂購一個零件。

列印日期 2017/11/17

型號 EM4350UH 引擎割草機4ST/43CC

分解圖號	零件編號	品名	交換	數量	N/O	選擇1	選擇2	註記
055	126260-7	齒輪組 F/EM4350UH		1	*			
D10		INC. 56-64,68-73			*			
055-1	126310-8	齒輪座組	O	1				
D10		INC. 56-64,68-73						
056	213459-4	O 形環 32		1				
057	188865-1	CUTTER SHAFT SET		1	*			
057-1	187644-4	刀具車心組	O	1				
058	211064-1	軸承6000		1				
059	211062-5	培林 6000ZZ		1				
060	961006-2	擋圈 S-10		1				
061	962105-3	擋圈R-26		1				
062	922353-6	內六角螺絲M6X30		1				
063	265590-2	+六角螺栓 M8X10 (W, R) R)		1				
064	210081-8	培林 629ZZ		1				
065	453883-1	離合器蓋		1				
066	125558-9	HANGER ASSEMBLY		1				
D10		INC. 67						
067	266698-5	HEX. SOCKET HEAD BOLT M5X20		1				
068	210116-5	培林6201LLU		1				
069	962151-6	擋圈 R-32		1				
070	331860-2	接收墊圈		1	*			
070-1	332114-0	RECEIVE WASHER	<	1				
071	346355-2	夾墊圈		1				
072	168526-9	護罩		1				
073	264025-0	六角螺帽 M10-17		1				
074	126163-5	控制桿		1				
D10		INC. 75-86,88,89						
075	188657-8	桿座組		1	*			
D10		INC. 87			*			
075-1	183A09-4	LEVER CASE SET	S	1				
D10		INC. 87						
076	233540-5	扭力彈簧 11		1				
077	451084-5	加油板機		1				
078	233541-3	扭力彈簧 7		1				
079	451083-7	固定桿		1				
080	453707-1	波紋管		1				
081	168740-7	控制電纜		1				
082	451081-1	纜線支架		1				
083	451500-7	開關桿		1				
084	232251-9	板片彈簧		1				
085	451253-8	開關蓋		1	*			
085-1	455723-9	SWITCH COVER	S	1				
086	638983-0	引線		1				
087	188657-8	桿座組		1	*			
D10		INC. 75			*			
087-1	183A09-4	LEVER CASE SET	S	1				
D10		INC. 75						
088	266326-2	螺絲 M4X18		3				

請訂購一個零件。

列印日期 2017/11/17

型號 EM4350UH 引擎割草機4ST/43CC

分解圖號	零件編號	品名	交換	數量	N/O	選擇1	選擇2	註記
089	638984-8	引線		1				
101	922233-6	螺栓 M5X20		1				
102	424302-4	塞蓋		1				
103	453535-4	汽缸蓋 C/455103-9		1	*			
103-1	455103-9	汽缸蓋	S	1				
104	922233-6	螺栓 M5X20		1				
105	453536-2	消音器蓋		1				
106	265995-6	攻牙螺絲 4X18		2				
107	922332-4	H.S.H.螺絲 M6X20		3				
108	168715-6	消音器		1				
109	346574-0	消音器墊片		1				
110	331987-8	排氣孔		1				
111	922226-3	螺栓 M5X18		4				
112	318850-2	外蓋		1				
113	422091-5	管5-160		1				
114	454424-6	波紋管		1				
115	453529-9	內蓋		1				
116	162335-8	背蓋墊片		1				
117	324891-8	火星塞帽彈簧		1				
118	168401-9	火星塞		1				
119	422090-7	管3-85		1				
120	452049-0	隔片		2				
121	135557-3	CYLINDER BLOCK ASSEMBLY		1	*			
D10		INC. 122-124			*			
121-1	135659-5	缸體總成	S	1				
D10		INC. 122-124						
122	424200-2	隔片		2				
123	424201-0	止回閥		2				
124	922342-1	H.S.H.螺絲 M6X25		8				
125	422099-9	管路		1				
126	282020-8	軟管夾		1	*			
126-1	282020-8	軟管夾	O	1				
127	424301-6	油管		1	*			
127-1	125805-8	油管組件	S	1				
C10	424301-6	油管		1				
D10		INC. 126,128						
128	325666-8	油配重		1	*			
128-1	325666-8	油配重	O	1				
129	162337-4	油箱墊片		1				
130	266760-6	螺栓 M5X18 (W, WRM) WRM)		3				
131	452047-4	油蓋		1				
132	424343-0	襯墊		1				
133	453538-8	油管		1				
134	162338-2	油管墊片		1				
135	318854-4	油箱		1				
136	922226-3	螺栓 M5X18		4				
137	346305-7	襯墊		1				
138	266611-3	螺栓 M6X8		1				

請訂購一個零件。

列印日期 2017/11/17

型號 EM4350UH 引擎割草機4ST/43CC

分解圖號	零件編號	品名	交換	數量	N/O	選擇1	選擇2	註記
139	346398-4	引導閥		1				
140	318851-0	輔助板		1				
141	922226-3	螺栓 M5X18		1				
142	325665-0	接管		1				
143	168724-5	管組		1				
144	454426-2	螺旋型形管 6-80		1				
145	163518-3	汽油濾清器		1				
146	282020-8	軟管夾		1				
150	126119-8	啟動拉繩組		1				
D10		INC. 151-157						
151	266634-1	固定螺絲 M6X20		1				
152	452288-2	REEL		1				
153	232262-4	螺旋彈簧		1				
154	424361-8	啟動柄		1				
155	424360-0	繩栓		1				
156	444027-4	啟動繩		1				
157	453534-6	STARTER COVER FOR EM4350UH		1				
158	922233-6	螺栓 M5X20		4				
160	126116-4	ROCKER ARM ASS'Y		2				
161	331990-9	COTTER		4				
162	331991-7	RETAINER		2				
163	234238-7	COMPRESSION SPRING 11		2				
164	256200-2	插銷 5		1				
165	256866-8	桿 2.5		2				
166	268238-5	插銷 5		1				
167	313236-5	升降器		2				
168	256186-0	插銷 5		1				
169	126115-6	齒輪組件		1	*			
169-1	126495-0	CAM GEAR ASSEMBLY	<	1	*			
169-2	126556-6	齒輪組件	<	1	*			
169-3	126571-0	CAMGEAR ASSEMBLY	<	1				
170	261127-3	TEFLON WASHER 10		1				
171	326158-0	EXHAUST VALVE		1	*			
171-1	326498-6	EXHAUST VALVE	S	1	*			
171-2	326575-4	EXHAUST VALVE	<	1				
172	326157-2	INTAKE VALVE		1				
173	196667-1	活塞環組		1				
174	233983-1	夾		2				
175	318853-6	活塞		1	*			
175-1	197455-9	PISTON SET	<	1				
C10	318853-6	活塞		1				
D10		INC. 173,174						
176	268285-6	活塞插銷		1				
177	213685-5	油封12		1				
178	126121-1	曲軸組		1				
D10		INC. 177,180,181						
179	254040-2	半圓鍵 3		1				
180	267425-3	FLAT WASHER 26		1				

請訂購一個零件。

列印日期 2017/11/17

型號 EM4350UH 引擎割草機4ST/43CC

分解圖號	零件編號	品名	交換	數量	N/O	選擇1	選擇2	註記
181	213537-0	OIL SEAL 12		1				
182	266086-6	六角螺絲M5X16 F/JR3020		4				
183	318856-0	齒輪蓋		1				
184	162334-0	齒輪蓋墊片		1				
185	638974-1	引線		1				
186	638975-9	引線		1				
187	444021-6	管路		1				
188	168714-8	點火線圈		1				
189	266602-4	螺栓 M4X20		2				
190	126122-9	飛輪組		1				
191	264075-5	COLLERD HEX NUT M8		1	*			
191-1	264039-9	盤形螺帽 M8-13	<	1	*			
191-2	264039-9	盤形螺帽 M8-13	<	1				
192	125728-0	油箱蓋組		1				
194	810455-9	警告板		1				
195	424081-4	緩衝器橡膠		1				
196	897220-3	SERIAL NO. LABEL		1				
198	922233-6	螺栓 M5X20		1				
199	261152-4	橡膠墊片 8		1				
200	331988-6	間隔		1				
201	168718-0	油箱		1	*			
201-1	168875-4	FUEL TANK	<	1				
202	922332-4	H.S.H.螺絲 M6X20		4				
203	318852-8	引擎		1				
204	266597-1	螺絲 M8		2				
205	267832-0	WAVE WASHER 10		2				
206	313238-1	離合器套		2				
207	231880-5	張力彈簧 5		2	*			
207-1	232290-9	TENSION SPRING 6	<	2				
208	267428-7	F墊圈8		2				
209	313239-9	離合器座		1				
210	346576-6	風葉盤		1				
211	266461-6	H.S.BUTTON HEAD SCREW M5X8		2				
212	453530-4	消音器片		1				
213	922233-6	螺栓 M5X20		1	*			
213-1	266760-6	螺栓 M5X18 (W, WRM) WRM)	<	1				
214	345918-1	軟管夾		1				
215	126118-0	濾清器蓋組 C/126474-8		1	*			
C10	801S44-5	INDICATION LABEL		1	*			
D10		INC. 216,217			*			
215-1	126474-8	濾清器蓋組	S	1	*			
C10	801S44-5	INDICATION LABEL		1	*			
D10		INC. 216,217			*			
215-2	126523-1	濾清器蓋總成	S	1				
D10		INC. 216,217						
216	266743-6	螺栓M5x20		1	*			
216-1	266743-6	螺栓M5x20	O	2				
217	898844-8	INDICATION LABEL		1				

請訂購一個零件。

列印日期 2017/11/17

型號 EM4350UH 引擎割草機4ST/43CC

分解圖號	零件編號	品名	交換	數量	N/O	選擇1	選擇2	註記
218	442181-8	空氣濾清器		1				
219	266601-6	螺栓 M5X60		2	*			
219-1	266601-6	螺栓 M5X60	S	2				
220	443173-0	空氣過濾器芯		1	*			
220-1	443196-8	空氣濾清器濾芯	S	1				
221	126117-2	CLEANER PLATE ASS'Y		1	*			
D10		INC. 222-226			*			
221-1	123994-3	CLEANER PLATE ASSEMBLY	S	1				
D10		INC. 222-226						
222	162346-3	分離器板		1				
223	352020-3	分離器護網		1				
224	266007-8	自攻螺絲 PT 3X10		1				
225	453865-3	分離器箱		1				
226	424316-3	止回閥		2				
227	454425-4	螺旋型形管 6-100		1				
228	422074-5	管路 3-120		1				
229	168398-2	注油幫浦		1				
230	442196-5	化油器墊片		1				
231	126339-4	化油器		1	*			
231-1	126339-4	化油器	O	1	*			
231-2	123301-0	化油器總成	<	1				
232	345963-6	固定夾		1				
233	266388-0	自攻螺絲 5X16		1				
234	442197-3	化油器墊片		1				
235	922233-6	螺栓 M5X20		2	*			
235-1	266814-9	螺絲 M5X20	<	2				
236	424489-2	金屬扣		1				
237	422080-0	管路 3-35		1				
238	142128-9	絕緣體組 C/142736-6		1	*			
238-1	142736-6	絕緣體組	S	1				
239	213642-3	O圈18		1				
240	819432-8	警告標籤		1				
241	898817-1	EM4350UH MODEL NO. LABEL		1				
242	451825-9	固定夾		1				
243	WJ00096589	螺絲總成		1				
244	WJ00021158	飾蓋計量隔板		1				
245	168620-7	計量膜片		1				
246	442183-4	計量隔板襯墊		1				
247	WJ00014477	插銷計量桿		1				
248	WJ00016648	固定橫桿		1				
249	WJ00983248	SPRING		1				
250	5416036160	PLUG-WELCH		1				
251	WJ00088229	塞蓋		1				
252	5806084330	STEEL BALL		1				
253	WJ00160593	ACCELERATOR PISTON ASSEMBLY		1				
254	WJ00983305	SPRING		1				
255	WJ00963240	SCREW		1				
256	WJ00343562	THROTTLE VALVE		1				

請訂購一個零件。

列印日期 2017/11/17

型號 EM4350UH 引擎割草機4ST/43CC

分解圖號	零件編號	品名	交換	數量	N/O	選擇1	選擇2	註記
257	WJ01023345	HIGH SPEED NEEDLE		1	*			
257-1	WJ01024009	NEEDLE (HIGH)	S	1				
258	WJ01023344	IDLE NEEDLE		1	*			
258-1	WJ01024008	NEEDLE IDLE	S	1				
259	WJ00025162	LIMITER CAP		1	*			
259-1	5106038120	WASHER	S	1				
260	257964-1	止動環 E-3		1				
261	WJ00098494	彈簧		1				
262	WJ00224392	THROTTLE SHAFT ASSEMBLY		1				
263	413140-9	墊片		1				
264	5246001210	轉環		1				
265	5016004110	SCREW		1				
266	WJ00008282	入口針閥		1				
267	WJ00001673	固定環		1				
268	WJ00183585	CHOKE LEVER		1				
269	WJ00044456	CHOKE SHAFT		1				
270	5806122210	SPRING		1				
271	5806122220	BALL		1				
272	WJ00006295	CHOKE VALVE		1				
273	WJ00096475	螺絲		1				
274	352010-6	入口濾網		1	*			
274-1	WJ00014070	過濾網	O	1				
275	WJ00009589	幫浦隔板		1				
276	WJ00092228	化油器墊片		1				
277	234183-6	錐形壓縮彈簧 5-9		1				
278	WJ00213807	PUMP COVER ASSEMBLY		1				
279	WJ00096166	螺絲		1				
280	WJ00098217	SPRING		1				
281	WJ00096368	IDLE ADJUST SCREW		1				
282	455102-1	轉換桿	S	1				
283	266385-6	螺絲4X14	S	1				
284	267485-5	F 華士 5	S	2				
A01	122906-3	條帶總成		1				
C10	140400-3	卡鉤組件		1				
A03	195501-2	四行程機油 100ml , API SL級 , SAE 10W		1	*			
A03-1	197008-4	OIL SET	O	1				
A04	782233-6	套管螺絲起子 10-16		1				
A05	783223-2	六角扳手 4		1				
A06	783232-1	六角扳手 5		1				
A07	782238-6	BOX WRENCH 17		1				
A08	831304-7	附件袋		1				
A09	122882-1	CUTTER ASSEMBLY		1				
E02	WJ00098404	彈簧	S	2				

請訂購一個零件。

列印日期 2017/11/17