

型號 DLS713 充電式圓鋸機-單機 18V

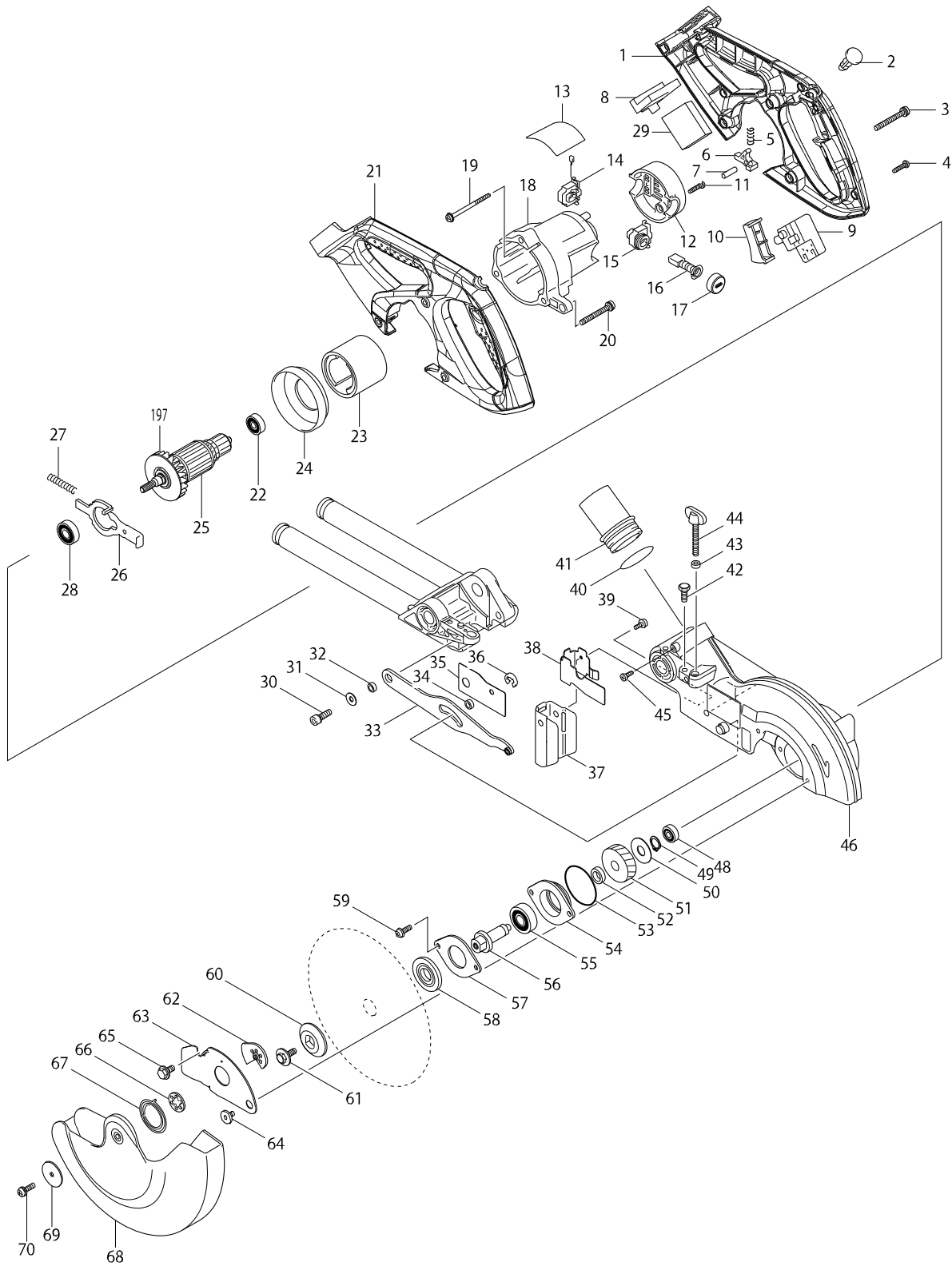

型號 DLS713 充電式圓鋸機-單機 18V

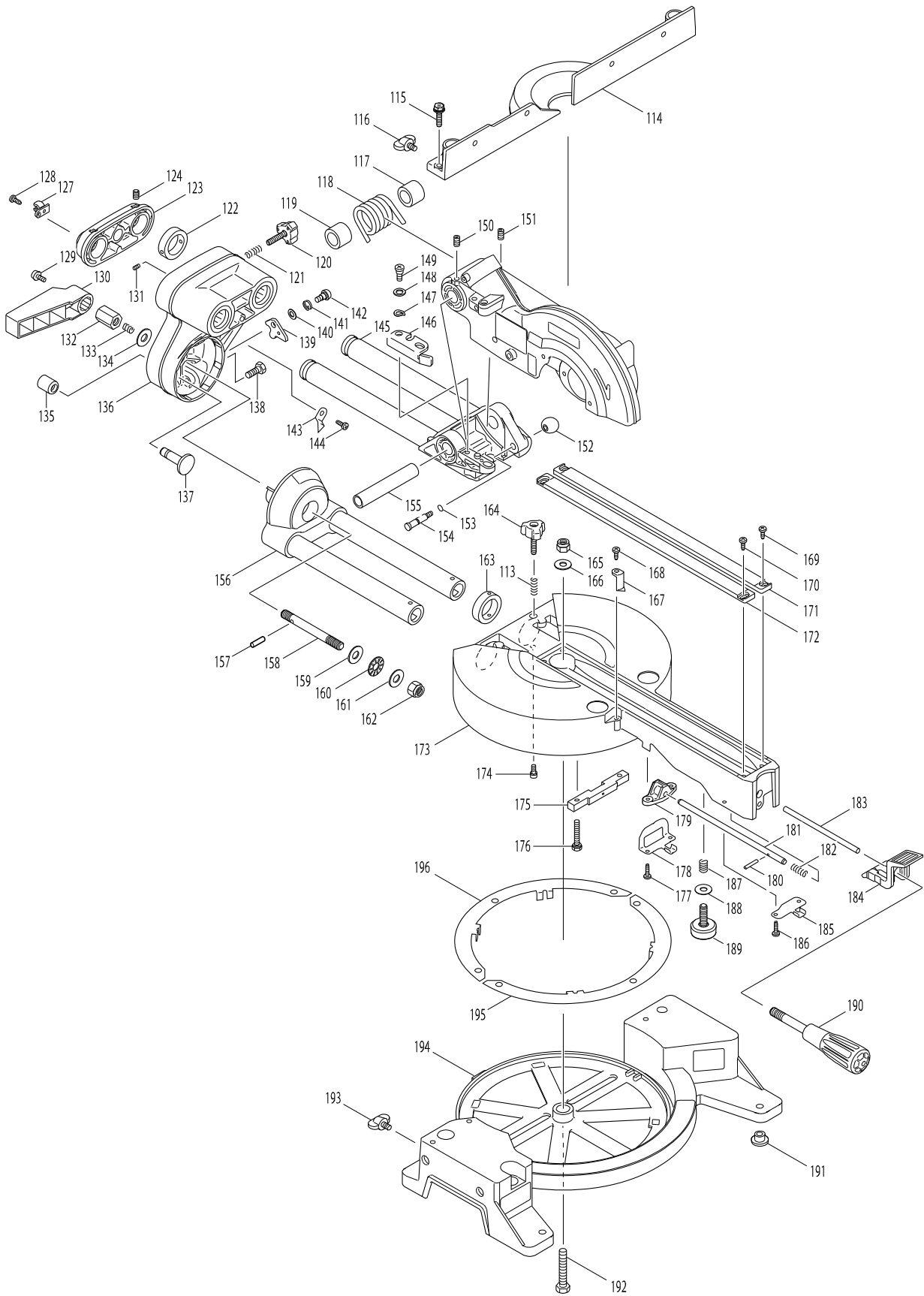

型號 DLS713 充電式圓鋸機-單機 18V

分解圖號	零件編號	品名	交換	數量	N/O	選擇1	選擇2	註記
001	188961-5	HANDLE SET		1				
	D10	INC. 21						
002	417113-4	安全按鈕 F/2414B		1				
003	911268-2	螺絲 M5X45		3				
004	265995-6	攻牙螺絲 4X18		5				
005	231026-3	彈簧 4		1				
006	416533-9	固定桿 F/LS0811		1				
007	256123-4	銷 5		1				
008	644808-8	電池端子		1				
009	651956-6	開關 TG72BD		1				
010	452130-7	SWITCH LEVER		1				
011	265995-6	攻牙螺絲 4X18		2				
012	416639-3	后端蓋		1				
013	815T55-0	DLS713 NAME PLATE		1				
014	643939-0	BRUSH HOLDER		1				
015	643966-7	BRUSH HOLDER		1				
016	194435-6	碳刷 CB-441		1				
017	643941-3	碳刷蓋		2				
018	416909-0	电机机壳		1				
019	266209-6	自攻螺絲 4X60		2				
020	911268-2	螺絲 M5X45		3				
021	188961-5	HANDLE SET		1				
	D10	INC. 1						
022	210023-2	培林 627DDW		1	*			
022-1	210045-2	滾珠軸承 627DDW	O	1				
023	632828-4	磁場環座		1				
024	416907-4	擋風板		1				
025	519269-0	ARMATURE ASS'Y 18V		1				
	D10	INC. 22,28,197						
026	344681-3	軸心擋片		1				
027	233092-6	扭力彈簧5		1				
028	211088-7	軸承6000DDW		1				
029	620263-8	CONTROLLER		1				
030	922331-6	H.S.H.螺絲 M6X20		1				
031	253804-1	平墊片 6		1				
032	257163-5	環6 F/LS1011		1				
033	154643-1	LINK PLATE COMPLETE		1				
034	257163-5	環6 F/LS1011		1				
035	346330-8	LINK COVER		1				
036	961018-5	停止圈 E-5		1				
037	424045-8	GUARD		1				
038	345438-5	防護板 F/LS0814FL		1				
039	911113-1	盤頭螺絲 M4X10		1				
040	213460-9	O圈 35		1				
041	419277-0	集塵接口 F/LS1013L,1214L		1				
042	266757-5	HEX. SOCKET HEAD BOLT M6X16		1				
043	262001-8	環5		1				
044	265717-4	螺絲 M6X43		1				

請訂購一個零件。

列印日期 2017/11/16

型號 DLS713 充電式圓鋸機-單機 18V

分解圖號	零件編號	品名	交換	數量	N/O	選擇1	選擇2	註記
045	266026-4	自攻螺絲 CT 4X12		1				
046	140699-0	BLADE CASE COMPLETE		1	*			
C10	263002-9	橡皮銷 4		1	*			
C20	263005-3	橡皮銷 6		1	*			
C30	810968-0	警告標		1	*			
046-1	143555-3	BLADE CASE COMPLETE	<	1				
C10	263002-9	橡皮銷 4		1				
C20	263005-3	橡皮銷 6		1				
C30	810968-0	警告標		1				
048	211021-9	軸承 607LLB		1				
049	961052-5	擋圈 S-12		1				
050	253813-0	F華士 12		1				
051	226512-7	斜齒輪60		1				
052	257011-8	環 12		1				
053	213623-7	○圈46 F/LF1000		1				
054	317193-9	軸承箱 F/LS0811		1				
055	211129-9	軸承 6201DDW		1				
056	323798-5	主軸		1				
057	285694-4	軸承保持板 F/LS0811		1				
058	224370-5	內法蘭士40 F/4131		1				
059	911223-4	螺絲 M5X16		2				
060	224275-9	外法蘭士 40 F/5008B		1				
061	266733-9	HEX. S.F.H. BOLT M6X16		1				
062	345585-2	中圈板 F/LS0814FL		1				
063	346232-8	CENTER COVER		1				
064	265985-9	螺母M6		1				
065	266732-1	HEX. SOCKET HEAD BOLT M6X16		1				
066	345589-4	中圈華士 F/LS0814FL		1				
067	231934-8	拉緊彈簧 24		1				
068	419123-7	SAFETY COVER		1				
069	267136-0	華士5		1				
070	911228-4	螺絲 M5X18		1	*			
070-1	265491-4	H.S. BUTTON HEAD BOLT M5X16	<	1				
113	231325-3	彈簧 F/LS0811		1				
114	318655-0	GUIDE FENCE		1				
115	922344-7	H.S.H.BOLT M6X25 WITH WG		3				
116	251887-5	螺絲M6X10		1				
117	416535-5	筒子17 F/LC0700		1				
118	231638-2	扭力彈簧28 F/LC0700		1				
119	416535-5	筒子17 F/LC0700		1				
120	265790-4	THUMB SCREW M6X28		1				
121	231325-3	彈簧 F/LS0811		1				
122	257214-4	圈26 F/LS0814FL		1				
123	318651-8	PIPE HOLDER		1				
124	266208-8	螺絲 M6X8		2				
127	687045-1	固定片		1				
128	266026-4	自攻螺絲 CT 4X12		1				
129	911113-1	盤頭螺絲 M4X10		1				

請訂購一個零件。

列印日期 2017/11/16

型號 DLS713 充電式圓鋸機-單機 18V

分解圖號	零件編號	品名	交換	數量	N/O	選擇1	選擇2	註記
130	416006-2	固定桿100 F/LS,LC		1				
131	913106-4	固定螺絲 M4X8		1				
132	252144-4	螺母M10-17		1				
133	231266-3	彈簧5		1				
134	253024-7	平面墊片10		1				
135	286236-7	帽 16 F/LS1211,LC1230		1				
136	140609-7	ARM COMPLETE		1				
C10	211376-2	培林2560 F/LS0814FL		2				
C20	262077-5	毛氈圈25 F/LS0814FL		4				
C30	263005-3	橡皮銷 6		2				
C40	344638-4	蓋35 F/LS0814FL		2				
137	324295-4	RELEASE PIN		1				
138	266757-5	HEX. SOCKET HEAD BOLT M6X16		2				
139	345299-3	STOPPER PLATE		1				
140	253726-5	F華士 6		1				
141	231663-3	TORSION SPRING 8		1				
142	265113-6	+PAN HEAD SCREW M5		1				
143	343678-9	指標板 F/LS1211		1				
144	266026-4	自攻螺絲 CT 4X12		1				
145	140608-9	FRONT ARM COMPLETE		1				
146	344643-1	制止器 F/LS0811		1				
147	253948-7	波形墊片8		1				
148	253835-0	平面墊片 8		1				
149	251267-5	螺絲M6		1				
150	251961-9	六角承窩固定螺絲(平端)M6X1		1				
151	251961-9	六角承窩固定螺絲(平端)M6X1		1				
152	271601-3	球型拉柄 20 F/M435		1				
153	213021-5	O圈 5		1				
154	324183-5	止動銷 F/LS0811		1				
155	331350-5	鋼管1690 F/LS1011		1				
156	140610-2	ARM HOLDER COMPLETE		1				
C10	816392-5	BEVEL SCALE LABEL		1				
157	256123-4	銷 5		1				
158	266320-4	SCREW M10		1				
159	253024-7	平面墊片10		1				
160	216413-7	針型培林 F/LS0814FL		1				
161	253024-7	平面墊片10		1				
162	252130-5	六角螺母M10-17		1				
163	257214-4	圈26 F/LS0814FL		1				
164	265790-4	THUMB SCREW M6X28		1				
165	252105-4	六角螺母 M8-13		1				
166	253731-2	平面墊片8 F/LC1230,0700		1				
167	416355-7	指針片 F/LS0811		1				
168	266026-4	自攻螺絲 CT 4X12		1				
169	266026-4	自攻螺絲 CT 4X12		2				
170	266026-4	自攻螺絲 CT 4X12		2				
171	419103-3	刀片 F/LS0814FL		1				
172	419103-3	刀片 F/LS0814FL		1				

請訂購一個零件。

列印日期 2017/11/16

型號 DLS713 充電式圓鋸機-單機 18V

分解圖號	零件編號	品名	交換	數量	N/O	選擇1	選擇2	註記
173	140614-4	TURN BASE COMPLETE		1				
C10	211376-2	培林2560 F/LS0814FL		2				
C20	262077-5	毛氈圈25 F/LS0814FL		4				
C30	263005-3	橡皮銷 6		1				
C40	344638-4	蓋35 F/LS0814FL		2				
C50	817283-3	注意標		2				
C60	810495-7	注意標籤		1				
174	922111-0	螺絲M4X10		1				
175	153580-6	SQUARE ROD COMPLETE		1				
C10	263005-3	橡皮銷 6		1				
176	925251-3	螺絲M5X30 F/LS0814FL		2				
177	266034-5	螺絲 4X16		2				
178	344601-7	鎖定板 F/LS0814FL		1				
179	317616-7	銷支架 F/LS0814FL		1				
180	256158-5	插銷 3		1				
181	324288-1	鎖定銷 F/LS0814FL		1				
182	231325-3	彈簧 F/LS0811		1				
183	324289-9	桿6 F/LS0814FL		1				
184	416450-3	鎖定槓桿 F/LS0814FL		1				
185	345272-3	鎖定槓桿板 F/LS0814FL		1				
186	266034-5	螺絲 4X16		2				
187	231418-6	壓縮彈簧 9		1				
188	253731-2	平面墊片8 F/LC1230,0700		1				
189	266432-3	調整螺絲 M8X27		1				
190	273658-0	把手32 F/LS0814FL		1				
191	286212-1	帽 20 F/LS1011,1211		5				
192	921472-5	螺絲M8X50 F/LS0814FL		1				
193	251887-5	螺絲M6X10		2				
194	140612-8	BASE COMPLETE		1				
C10	816339-9	斜接面刻度板 F/LS0814FL		1				
C20	810486-8	注意標籤		1				
195	344646-5	邊環 F/LS0811		1				
196	344646-5	邊環 F/LS0811		1				
197	241873-4	風葉 55 F/6922NB		1				
A01	122571-8	虎鉗組 F/LS0814FL		1				
C10	316938-2	夾具組 F/LS1211		1				
C20	251887-5	螺絲M6X10		1				
C30	322313-2	鉗桿 F/LS1011		1				
C40	265733-6	螺絲M10X60 F/LS0814FL		1				
C50	253804-1	平墊片 6		1				
C60	343651-9	鉗板 F/LS1011		1				
C70	251370-2	螺絲M5		1				
A02	122852-0	集塵袋總成		1				
C10	410602-8	集塵袋口蓋		1				
A03	762001-3	三角形		1				
A04	322312-4	把手 F/LS1011		2				
A05	783203-8	六角板手 5		1				

請訂購一個零件。

列印日期 2017/11/16