

型號 9533BL 平面砂輪機100MM

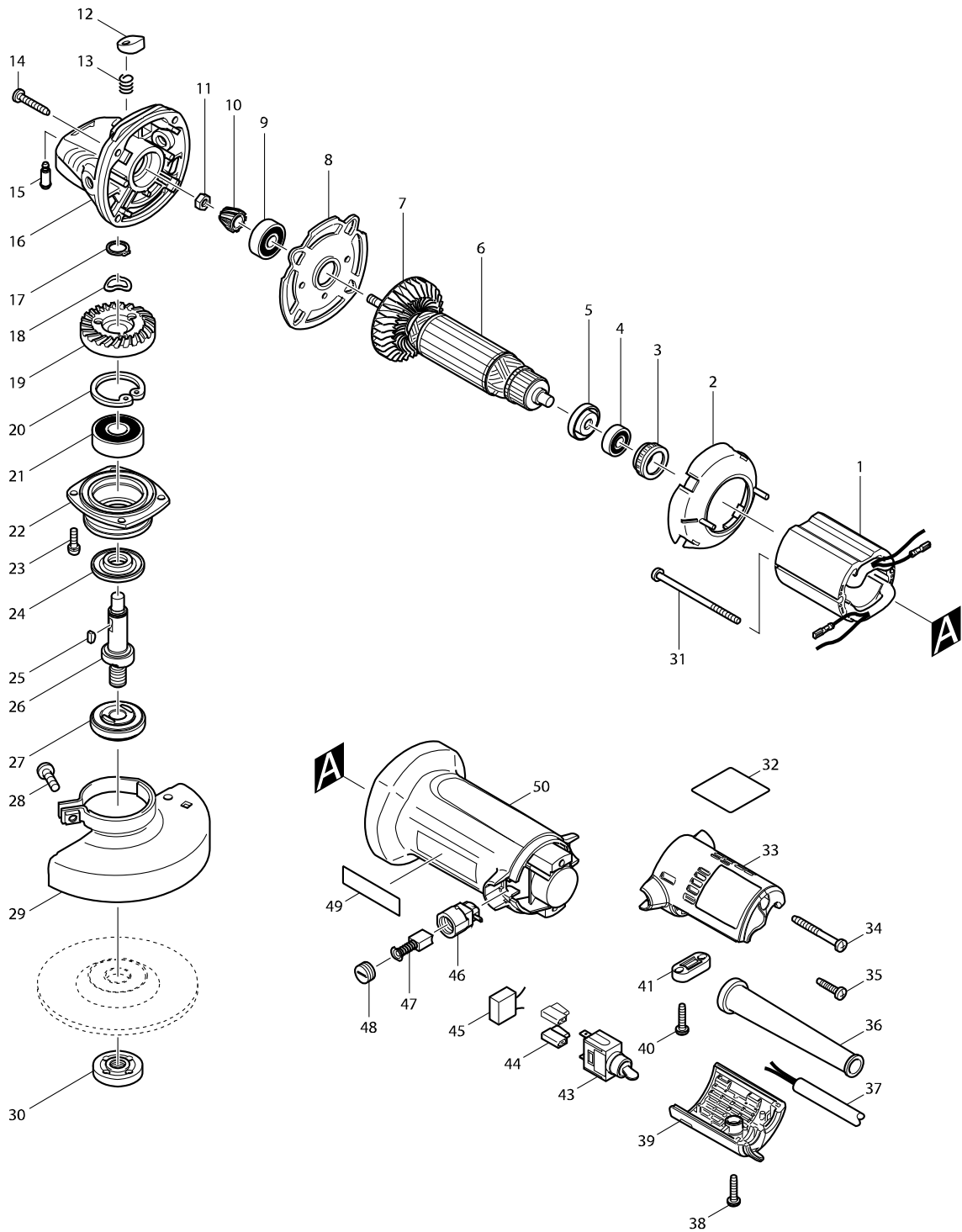

型號 9533BL 平面砂輪機100MM

分解圖號	零件編號	品名	交換	數量	N/O	選擇1	選擇2	註記
001	623501-7	外線圈 F/9533B,L		1				
002	418584-8	風葉座 F/9533B&L		1				
003	421494-0	橡皮圈19 F/DP4010,9520B		1				
004	210017-7	培林 607DDW		1				
005	681636-0	絕緣華士		1				
006	517586-2	馬達心 F/9533B,BL		1				
D10		INC. 3-5,7						
007	240071-7	風葉54 F/9533B,BL		1				
008	285712-8	軸承保持板40 F/9553B,BL		1				
009	210032-1	軸承 F/9533B,BL		1				
010	227462-9	傘型齒輪9 F/9533BL		1				
011	252137-1	螺絲 M5X8		1				
012	415491-6	固定扭帽 F/952XB,M958		1				
013	233072-2	彈簧8 F/9520B,MT950-4		1				
014	265999-8	螺絲 4X25		4				
015	256437-1	銷 4 F/9520B,M958		1				
016	153846-4	齒輪箱 F/9533B,BL		1				
017	961052-5	擋圈 S-12		1				
018	253904-7	W華士12		1				
019	227466-1	螺旋齒輪38 F/9533BL		1				
020	962151-6	擋圈 R-32		1				
021	211149-3	軸承 F/9533B,BL		1				
022	316600-9	軸承箱 F/9520B,9533B,L		1				
023	911121-2	螺絲M4X14		4	*			
023-1	265168-1	螺絲M4X14 F/9533B	<	4				
024	415492-4	內圈 F/9520B,9533B		1				
025	254011-9	半圓鍵4		1				
026	324451-6	軸心桿 F/9533B,BL		1	*			
026-1	326026-7	SPINDLE	<	1				
027	224314-5	內法蘭士 30		1	*			
027-1	224491-3	INNER FLANGE 29	S	1				
028	251391-4	盤頭螺釘 M5×16		1				
029	165187-6	安全蓋		1	*			
029-1	123537-1	WHEEL COVER 100T ASS'Y	X	1				
C10	808C45-8	CAUTION LABEL		1				
030	224559-5	螺母 10-30		1	*			
030-1	224493-9	LOCK NUT 10-29	S	1				
031	266004-4	自攻螺絲 4X70		2				
032	860964-8	NAME PLATE 9533BL		1				
033	183983-0	尾部蓋組 F/9533B,BL		1				
D10		INC. 39						
034	266048-4	螺絲4X40		1				
035	265995-6	攻牙螺絲 4X18		1				
036	682566-8	電線保護管10		1				
037	693464-1	電線 0.75-2-2.5		1				
038	265995-6	攻牙螺絲 4X18		1				
039	183983-0	尾部蓋組 F/9533B,BL		1				
D10		INC. 33						

請訂購一個零件。

列印日期 2017/11/03

